

THIS SPACE FOR DESIGNER/ENGINEER APPROVAL

Job/Customer _____	Date _____	Contractor _____
Model Specified _____	Qty _____	Approved By _____
Designer/Engineer _____	Date _____	Contractor's PO# _____
Submitted by _____	Date _____	Other _____

4444 Series

Isolator® E-X-P E2™

Tankless Water Heater Service Valve Kits
Hot & Cold Set of Full Port Forged Brass Ball Valves
w/ Hi-Flow Hose Drains & Pressure Relief Valve Outlet
IPS Union x IPS
500 WOG



Includes Residential or Commercial Pressure Relief Valve

ITEM #	SIZE	CTN	CASE	A	B	C	D	E	F	G
RESIDENTIAL PRESSURE RELIEF VALVE (150 PSI/200,000 BTU)										
44443PR	3/4	1	10	3/4	4 1/4	1 5/8	2 5/8	2 3/4	3/4	1/2
44444PR	1	1	10	1	5	2 3/8	2 3/8	2 3/4	3/4	3/4
RESIDENTIAL PRESSURE RELIEF VALVE (30 PSI/200,000 BTU)										
44443PR3	3/4	1	10	3/4	4 1/4	1 5/8	2 5/8	2 3/4	3/4	1/2
COMMERCIAL PRESSURE RELIEF VALVE (150 PSI/2,703,000 BTU) & 3/4" CLOSE NIPPLE										
44443PR2	3/4	1	6	3/4	4 1/4	1 5/8	2 5/8	2 3/4	3/4	1/2
44444PR2	1	1	6	1	5	2 3/8	2 3/8	2 3/4	3/4	3/4



PATENTED TECHNOLOGY
 The service valves in these kits are certified to **NSF/ANSI 61-8**

NO.	DESCRIPTION	MATERIAL
1	BODY	BRASS
2	SEATS	PTFE
3	BALL	BRASS HCP
4	HANDLE NUT	STAINLESS STEEL
5	WING STYLE "T" HANDLE	STEEL CP
6	HANDLE JACKET	VINYL
7	PACKING GLAND	BRASS
8	STEM SEAL	PTFE
9	STEM	BRASS
10	END CAP	BRASS
11	UNION NUT	BRASS
12	RETAINING RING	STAINLESS STEEL
13	UNION FITTING	BRASS
14	WASHER	EPDM
15	DRAIN VALVE HANDLE	ENAMEL COATED ALUMINUM
16	DRAIN VALVE HANDLE SCREW	BRASS
17	CAP & STRAP	BRASS W/ EPDM HOSE WASHER

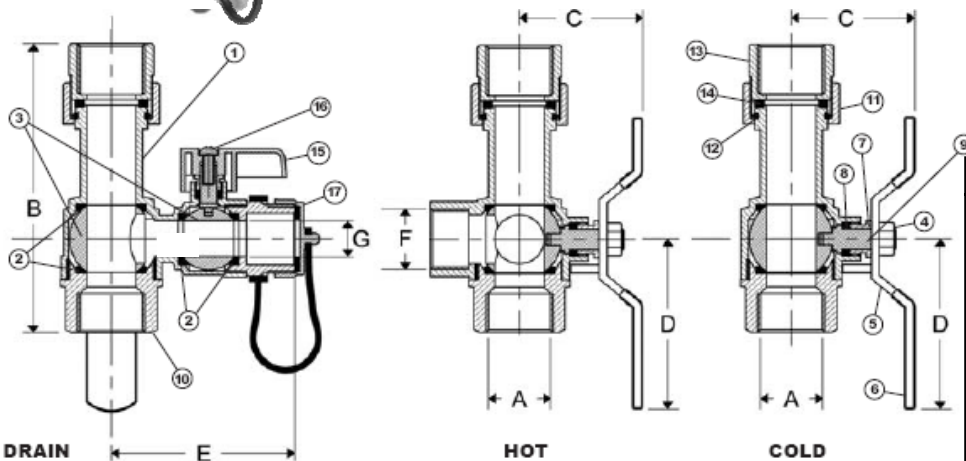

TEMP °F	PSI
100	500
150	408
180	398

Included w/ 4444PR & PR3	Included w/ 4444PR2
<p>Residential Pressure Relief Valve Available in 30 PSI or 150 PSI 200,000 btu</p>	<p>Commercial Pressure Relief Valve 150 PSI / 2,703,000 btu & 3/4" Close Nipple</p>

Specifications: Designed for residential or commercial use with potable water. This approved Webstone valve is actuated by a blowout proof stem and features an adjustable packing gland. Threaded ends comply with ANSI B1.20.1.



Quality and Commitment Since 1954

Webstone product specifications in U.S. customary units are approximate and are provided for reference only. Webstone reserves the right to change or modify product design, construction, specifications or materials without prior notice and without incurring any obligation to make such changes and modifications on Webstone products previously or subsequently sold.