



HI-EFFICIENT DIRECT VENT WALL FURNACE



INSTALLATION AND OPERATING INSTRUCTIONS



P/N 72903 / JUNE 2015

MODEL NUMBERS		
NAT. GAS	HEDV253A	HEDV403A
L.P. GAS	HEDV254A	HEDV404A

INSTALLER: Leave this manual with the appliance.

CONSUMER: Retain this manual for future reference.

Remove cabinet to access gas control knob.

WARNING: If the information in these instructions are not followed exactly, a fire or explosion may result causing property damage, personal injury or death.

- Do not store or use gasoline or other flammable vapors and liquids in the vicinity of this or any other appliance.
- **WHAT TO DO IF YOU SMELL GAS:**
 - Do not try to light any appliance.
 - Do not touch any electrical switch; do not use any phone in your building.
 - Immediately call your gas supplier from a neighbor's phone. Follow the gas supplier's instructions.
 - If you cannot reach your gas supplier, call the fire department.
- **INSTALLATION AND SERVICE MUST BE PERFORMED BY A QUALIFIED INSTALLER, SERVICE AGENCY OR THE GAS SUPPLIER.**

HEDV25

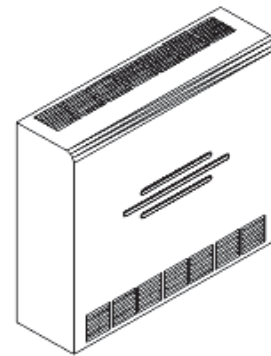
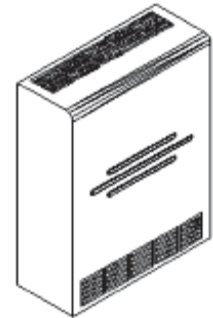

HEDV40



MADE IN U.S.A.

WARNING: Operation of this furnace without the properly installed, factory furnished vent system and vent cap could result in Carbon Monoxide (CO) poisoning and possible death. For your safety, this furnace and the vent system should be inspected at least annually by a qualified service technician.

This appliance may be installed in an aftermarket, permanently located, manufactured home (USA only) or mobile home, where not prohibited by local codes. This appliance is only for use with the type of gas indicated on the rating plate. This appliance is not convertible for use with other gases, unless a certified kit is used.

This unit is for residential use only and is not approved for installation in greenhouses, or environments involving dusty, wet, corrosive, or explosive conditions. Such conditions will invalidate the warranty and may create unsafe conditions.

Installation, maintenance, service, trouble shooting and repairs must be performed by a qualified service agency. Mr./Mrs. Homeowner, **do not** attempt any of these procedures yourself as this could expose you to property damage, personal injury, or loss of life and will invalidate all warranties.

The State of Massachusetts requires that installation and service of a gas appliance be performed by a plumber or gas fitter licensed in the Commonwealth of Massachusetts.

CONTENTS

Introduction.....	2	Removing Main Burner.....	11
Specifications and Dimensions.....	2	Proper Burner Flame.....	11
Safety Rules.....	3	Wiring Diagram.....	12
Clearances.....	4/5	Sequence of Operation.....	13
Location.....	6/7	Optional Kits.....	14/16
Installation.....	7/9	Maintenance Instr./Service Record.....	17
Lighting Instructions.....	10	Trouble Shooting.....	18/19
Burner Orifice.....	11	Parts Drawing.....	20
		Parts List	21
		Warranty.....	22

INTRODUCTION

THIS IS A GAS-FIRED DRAFT INDUCED, POWER DEPENDENT DIRECT VENT WALL FURNACE THAT WILL OPERATE SAFELY AND PROVIDE AN EFFICIENT SOURCE OF HEAT WHEN INSTALLED, OPERATED AND MAINTAINED AS RECOMMENDED IN THESE INSTALLATION AND OPERATING INSTRUCTIONS. READ THESE INSTRUCTIONS THOROUGHLY BEFORE INSTALLING, SERVICING, OR USING THE APPLIANCE. IF YOU DO NOT UNDERSTAND ANY PART OF THESE INSTRUCTIONS CONSULT LOCAL AUTHORITIES, OTHER QUALIFIED INSTALLER, SERVICE TECHNICIAN, THE GAS SUPPLIER OR THE MANUFACTURER.

SPECIFICATIONS AND DIMENSIONS

Your Direct Vent Wall Furnace is shipped complete in one carton. This carton contains the furnace, vent cap, collector box, vent exhaust tube, air inlet tube, wall template with rough-in dimensions, installation and operating instructions, and wall thermostat.

Model No.	Input BTU/HR	Weight	Width	Depth	Height	Type Control	CFM	AMPS	Gas Conn.	Center Vent to Floor (Adj.)	MAX. Wall	MIN. Wall
											THICKNESS	
<u>NATURAL GAS</u>												
HEDV253A	25,000	100 Lbs.	24-1/2"	9-3/4"	32-1/4"	24 V.	200	1.88	3/8"	12-1/2"	32"	5"
HEDV403A	40,000	120 Lbs.	34-5/8"	9-3/4"	30-1/2"	24 V.	500	2.18	3/8"	12-1/2"	32"	5"
<u>L.P. GAS</u>												
HEDV254A	25,000	100 Lbs.	24-1/2"	9-3/4"	32-1/4"	24 V.	200	1.88	3/8"	12-1/2"	32"	5"
HEDV404A	40,000	120 Lbs.	34-5/8"	9-3/4"	30-1/2"	24 V.	500	2.18	3/8"	12-1/2"	32"	5"

SAFETY RULES

1. Improper installation, adjustment, alteration, service, or maintenance can cause property damage, bodily injury, or death.
2. Use in other than a residential application may result in unsatisfactory performance, may create unsafe conditions and will invalidate the warranty.
3. The installation must conform with local codes or in the absence of local codes with the National Fuel Gas Code, ANSI Z223.1/NFPA 54, Natural Gas and Propane Installation Code, CSA B149.1.
4. **DO NOT INSTALL THIS FURNACE IN A RECREATIONAL VEHICLE OR TRAILER.**
5. Do not operate wall furnace unless it is connected to the factory supplied vent system with vent cap in place.
6. Check the rating label attached to the wall furnace to be sure it is equipped for the type gas you intend to use.
7. Never use a match, candle, flame or other source of ignition to check for gas leaks. Use only soapy water or liquid detergent.
8. Have your wall furnace and vent system inspected at least annually by a qualified service technician.
9. Before cleaning or servicing, turn off the gas and allow furnace to cool.
10. Do not operate wall furnace without all components properly installed (top, front, etc.).
11. Due to high temperatures, the appliance should be located out of traffic and away from furniture and drapes.
12. Children and adults should be alerted to the hazards of high surface temperature and should stay away to avoid burns or clothing ignition.
13. Young children should be carefully supervised when they are in the same room as the appliance.
14. Clothing or other flammable material should not be placed on or near the appliance.
15. INSTALLATION AND REPAIR SHOULD BE DONE BY A QUALIFIED SERVICE TECHNICIAN. THE APPLIANCE SHOULD BE INSPECTED BEFORE USE AND AT LEAST ANNUALLY BY A QUALIFIED SERVICE TECHNICIAN. More frequent cleaning may be required due to excessive lint from carpeting, bedding material, etc. It is imperative that control compartments, burners, and circulating air passageways of the appliance be kept clean.
16. Do not install in a closet, alcove, or small hallway where the furnace could be isolated from the space to be heated by closing a door.
17. Do not put anything around the furnace or vent cap that will obstruct the flow of combustion and ventilation air.
18. The appliance, when installed, must be electrically grounded in accordance with local codes or, in the absence of local codes, with the latest edition of National Electrical Code, ANSI/NFPA 70, or Canadian Electrical Code, CSA C22.1, if an external electrical source is utilized.
19. Never operate this furnace without the sight glass in place or with the glass broken or missing.
20. If it is suspected that rising water may enter the furnace, turn off the gas immediately.
21. Do not use this appliance if any part has been under water. Immediately call a qualified service technician to inspect the appliance and to replace any part of the control system and any gas control which has been under water.
22. It is necessary to replace damaged gaskets or sealing material within the vent or air intake system. Failure to do so may result in property damage, personal injury or loss of life.
23. Any safety screen or guard removed for servicing must be replaced prior to operating heater.
24. A gas appliance must not be connected to a chimney flue serving a separate solid fuel burning appliance.
25. The appliance area must be kept clear and free from combustible materials, gasoline and other flammable vapors and liquids.
26. Any safety screen or guard removed for servicing an appliance must be replaced prior to operating the appliance.

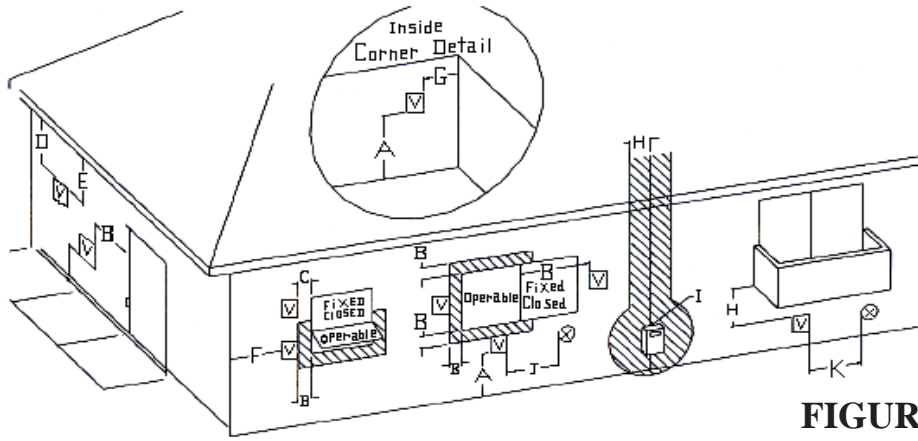

FIGURE 1

☑ Vent Terminal ⊗ Air Supply Inlet ▨ Area where terminal is not permitted

VENT TERMINAL CLEARANCES

REFERENCE LETTER TO DRAWING	CANADIAN INSTALLATIONS ¹	U.S. INSTALLATIONS ²
A = Clearance above grade, veranda, porch, deck, or balcony	12 Inches (30 cm)	12 Inches (30 cm)
B = Clearance to window or door that may be opened	12 Inches (30 cm)	9 Inches (23 cm)
C = Clearance to permanently closed window	12 Inches (30 cm)	9 Inches (23 cm)
D = Vertical clearance to ventilated soffit located above the terminal within a horizontal distance of 2 Feet (61 cm) from the center line of the terminal	18 Inches (46 cm)	18 Inches (46 cm)
E = Clearance to unventilated soffit	18 Inches (46 cm)	18 Inches (46 cm)
F = Clearance to outside corner	12 Inches (30 cm)	12 Inches (30 cm)
G = Clearance to inside corner	12 Inches (30 cm)	12 Inches (30 cm)
H = Clearance to each side of center line extended above meter/regulator assembly	3 Feet (91 cm) within a height 15 Feet (4.5m) above the meter/regulator assembly	Clearances are in accordance with local installation codes and the requirements of the gas supplier
I = Clearance to service regulator vent outlet	3 Feet (91 cm)	Clearances are in accordance with local installation codes and the requirements of the gas supplier
J = Clearance to nonmechanical air supply inlet to building or the combustion air inlet to any other appliance	12 Inches (30 cm)	12 Inches (30 cm)
K = Clearance to a mechanical air supply inlet	6 Feet (1.83 m)	3 Feet (91 cm) above if within 10 Feet (3 m) horizontally
L = Clearance above paved sidewalk or paved driveway located on public property	7 Feet (2.13m) A vent shall not terminate directly above a sidewalk or paved driveway that is located between two single family dwellings and serves both dwellings.	Clearances are in accordance with local installation codes and the requirements of the gas supplier.
M = Clearance under veranda, porch, deck, or balcony	12 Inches (30 cm) permitted only if veranda, porch, deck, or balcony is fully open on a minimum of two sides.	Clearances are in accordance with local installation codes and the requirements of the gas supplier.

¹ In accordance with the current CSA-B149.1 Natural Gas and Propane Installation Code

² In accordance with the current ANSI Z223.1 / NFPA 54 National Fuel Gas Code

ATTENTION ALL CANADIAN CONTRACTORS/INSTALLERS: Before installing this heater into a multi-family hi-rise exceeding four stories, contact the local building code inspector to verify the building construction complies with the **Progressive Collapse** requirements as listed in the National Building Code of Canada 2005.

CLEARANCES

1. As you face the heater, the clearance to a side wall on the right side is 0" (Fig. 2), and the left side is 1" (Fig. 2).
2. The minimum clearance from the top of the heater to the ceiling or any projecting overhang is 10". (See Figure 2).
3. The minimum clearance from the bottom of the heater to the floor, or the top surface of carpeting, tile, etc. is 0". (See Figure 2).
4. When the appliance is installed directly on carpeting, tile or other combustible material other than wood flooring, the appliance shall be installed on a metal or wood panel extending the full width and depth of the appliance.
5. The minimum clearance from the edge of the vent cap to any overhanging obstruction, perpendicular side wall, or corner of building is 12". (See Figure 1).
6. Vent cap must be located at least 9" from any opening that would allow combustion products to enter the building, windows, doors, etc., and 12" above the ground or shrubbery (See Figure 1). Do not install vent cap in a window well. Provisions must be made to prevent snow accumulation from infringing on vent cap clearances.
7. Clearances around vent cap must be maintained to assure adequate combustion and ventilation air.
8. Clearances listed are minimum. Adequate accessibility clearances for servicing must be maintained.

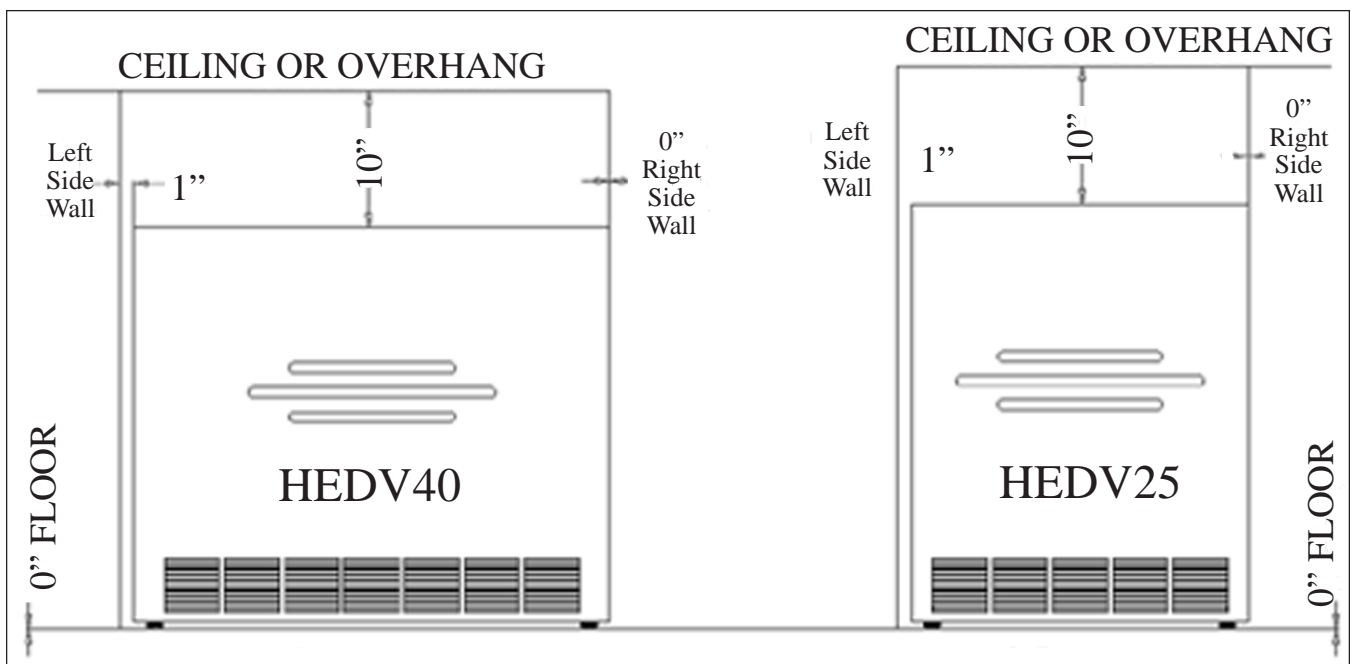

FIGURE 2

CLEARANCES

9. **RESIDENTIAL GARAGE INSTALLATION:** Gas utilization equipment in residential garages shall be installed so that all burners and burner ignition devices are located not less than 18 inches (46 cm) above the floor. You must build a platform 18" above floor, the full width and depth of the heater, including the rear trim kit. **HEATER IS NOT DESIGNED TO HANG ON WALL.** Unit should be located or protected so it is not subject to damage by a moving vehicle. Use care in selecting a good location within the garage. **DO NOT** locate the appliance where heated air will be directed onto a nearby parked vehicle. Paint may discolor or rubber may harden and crack. **DO NOT** allow open or closed containers of paint, gasoline or other liquids having flammable vapors to be stored or used in the same area as the heater.

LOCATION

1. The wall furnace must be installed on an outside wall, unless optional Kit No. HEVK-5 is used.
2. For most efficient performance, locate furnace as centrally as possible in the area to be heated and where occupants may move about freely without coming into contact with the cabinet, and within reach of a 115V wall outlet.
3. If the furnace is installed in a basement, a 12" clearance must be maintained between ground level and the bottom of the vent cap. Do not install furnace where vent cap will terminate in a window well or any other opening below ground level. (See Figure 3). Do not allow snow accumulation to build up within 12" of the vent cap.

OPTIONAL KITS

1. HEVK-5 - To extend vent 5 foot from heater. This will allow vent cap to be installed above grade from basement or to an outside wall. A total of 3 kits with 2 additional elbows may be used.

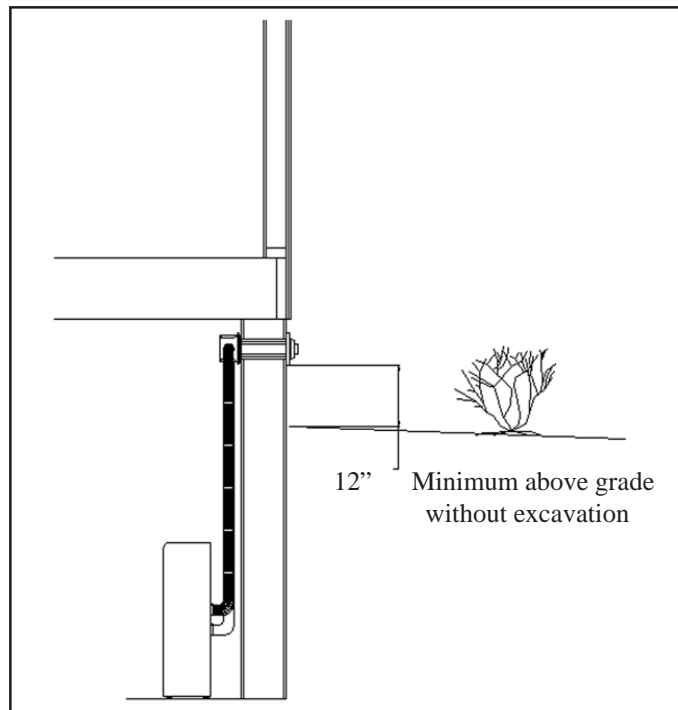

FIGURE 3

ATTENTION ALL CANADIAN CONTRACTORS/INSTALLERS: Before installing this heater into a multi-family hi-rise exceeding four stories, contact the local building code inspector to verify the building construction complies with the **Progressive Collapse** requirements as listed in the National Building Code of Canada 2005.

INSTALLATION

Failure to follow these instructions carefully could result in poor performance, property damage, personal injury, or death.

STEP 1. LOCATE VENT OPENING (Requires 3-1/2" diameter wall opening)

- Select area on wall where heater will be installed. Using template (packed with heater) mark shaded area where hole can be cut and to locate the wall brackets. (See Figure 4).
- Locate studs on each side of this area.
- Mark location for 3-1/2" diameter hole between studs. Hole should be offset to miss studs. (See Fig. 4).
- Check outside wall at this location for proper clearances around vent cap. (See Fig. 1).
- Cut vent openings into both the inside and outside walls, being sure to maintain level across both openings.

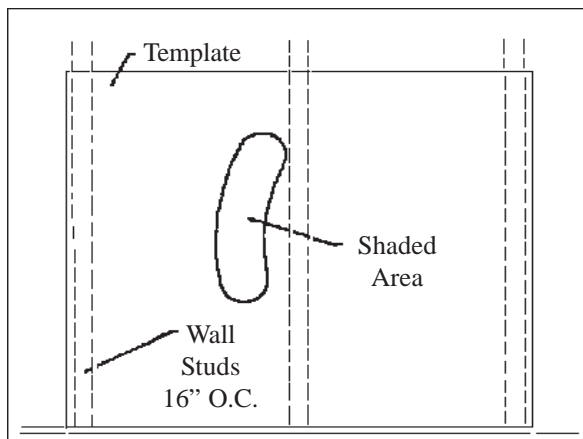

FIGURE 4

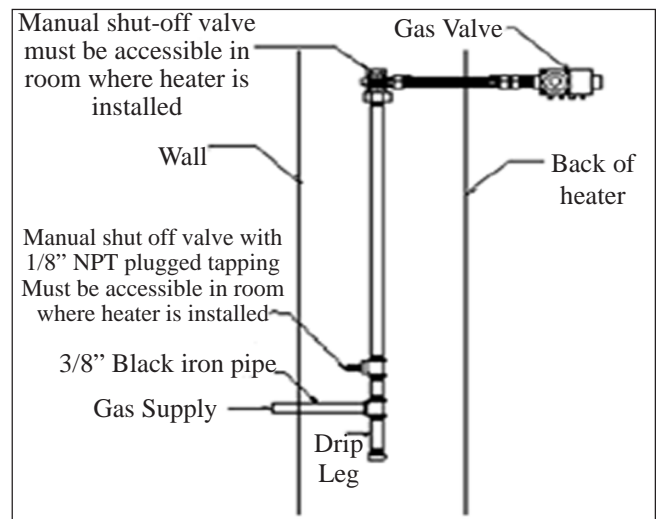

FIGURE 5

STEP 2. ROUGH-IN GAS SUPPLY (See Figure 5)

Install at least 3/8" gas supply line. Contact local gas supplier if any questions.

Install a drip leg in gas supply line immediately upstream from the gas connection to heater (see local codes), and provide a 1/8" N.P.T. plugged tapping, accessible for test gauge connection and an individual manual shut off valve accessible within room where heater is installed. (See Figure 5). The heater and its individual shut off valve must be disconnected from the gas supply piping system during any pressure testing of that system at test pressures in excess of 1/2 psig (3.5Pa). The heater must be isolated from the gas supply piping system by closing its individual manual shut off valve during any pressure testing of the gas supply piping system at test pressures equal to or less than 1/2 psig (3.5Pa). Test all connections for leaks using a soapy solution. **NEVER USE AN OPEN FLAME TO TEST FOR LEAKS.**

The maximum inlet gas supply pressure for Natural or L.P./Propane gas is 1/2 p.s.i. or 14" w.c.

The minimum inlet gas supply pressure for the purpose of adjustment is 4.5" w.c. for Natural gas or 11.0" w.c. for L.P./Propane gas.

INSTALLATION - CONTINUED

STEP 3 INSTALLING VENT SYSTEM 5" - 32" WALL THICKNESS (12.7 cm - 81.3 cm)

- a) Use only factory supplied parts. Do not attempt to modify in any way. To do so could cause a system imbalance resulting in poor performance and/or unsafe operating conditions.
- b) Slide collection box pipes through cutout and secure collection box to inside wall. Anchors (not supplied) may be required. (See Figure 5).
- c) From outside house, mark collection box pipes and cut off 1/2" beyond outside wall.
- d) Slide vent cap pipes onto collection box pipes and push in until flange is flush against house. Secure vent cap assembly to outside wall with a slight downward slope. This will prevent water from entering and allow condensation to drain. Caulk around the edges of the vent cap mounting plate. NOTE: It may be necessary to build a metal or wood frame to provide a flat surface for the mounting plate to be flush against or to attain the 5" minimum wall thickness.

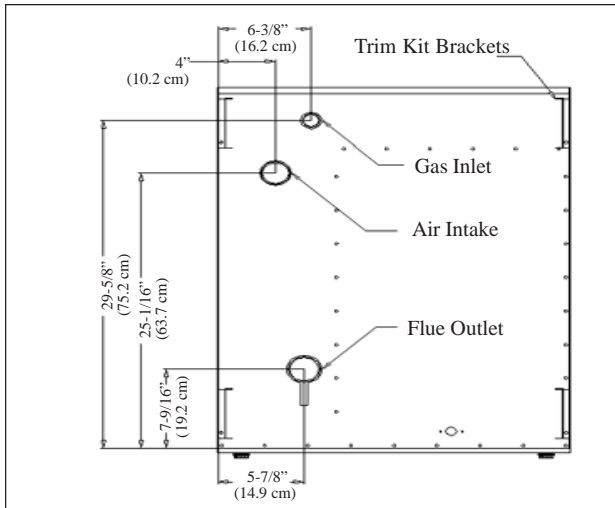

HEDV25 - Figure 6

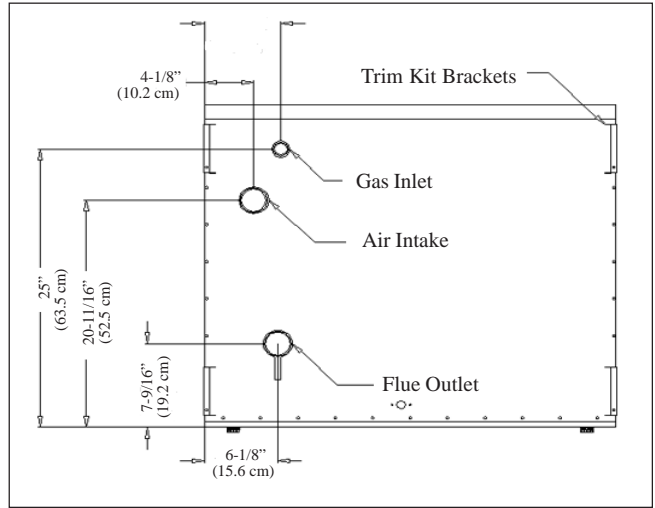

FIGURE 5

HEDV40 - Figure 6

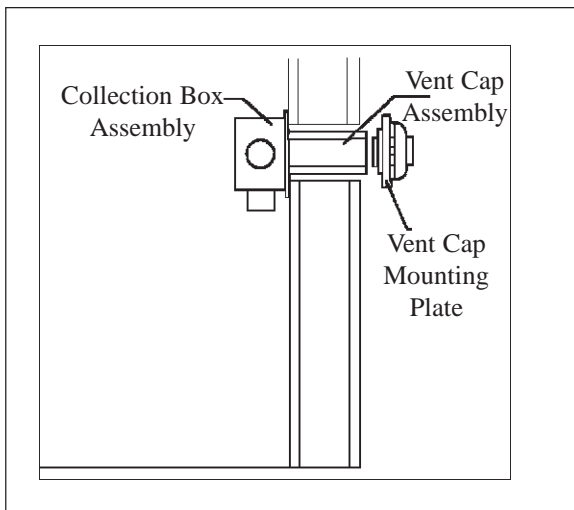

FIGURE 7

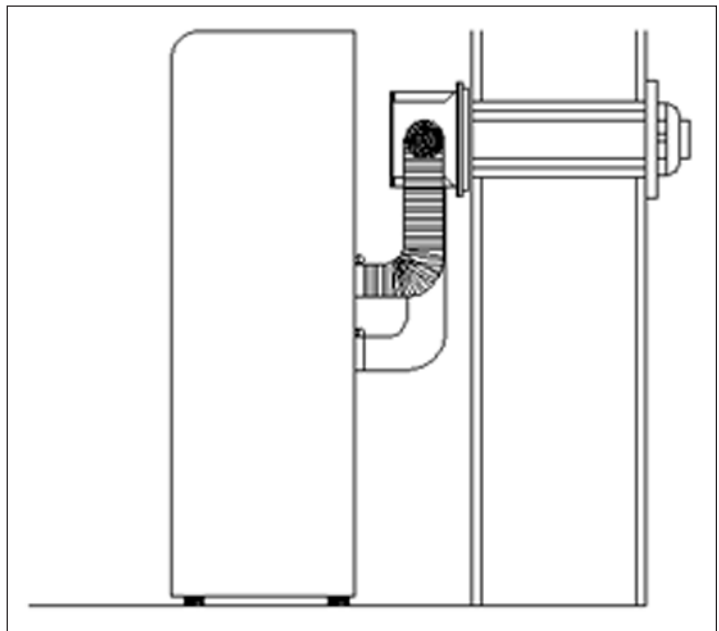

FIGURE 8

STEP 4. INSTALLING HEATER

- a) Locate (and mark) wall mounting bracket location on wall using template supplied.
- b) Secure wall brackets to wall, anchors (not provided) may be required.
- c) Secure trim kit brackets to back of heater using eight #8 screws provided. (See Figure 9).
- d) Slide heater to approximately 5" of wall.
- e) Secure air intake hose to back of heater and the collector box assembly using hose clamps provided. (See Figure 8).
- f) Secure vent exhaust tube to exhaust tube on back of heater and the exhaust tube on the collection box assembly using hose clamps provided. (See Figure 8).
- g) Connect 3/8" minimum gas supply line to manual cut-off valve on back of the heater. (See Figure 5).
- h) Locate factory installed thermostat wires extending from rear of the heater. Connect 24 V. thermostat wall thermostat (provided) using a maximum 20' of thermostat wire. Do NOT splice thermostat wire.
- i) Secure right and left trim side panels to the wall and trim kit brackets with eight #8 screws provided. (See Figure 9). This will space the back of the heater 5" from the wall.
- j) Secure trim top to trim sides using four #8 screws provided.
- k) Plug three-pronged factory wired power cord into a properly grounded 115 Volt electrical outlet. NEVER use an extension cord. If homeowner desires, heater can be hard wired by a licensed electrician. See local electrical codes.
- l) Turn the manual gas control valve on. Check all connections for leaks using a soapy solution. NEVER check for leaks with an open flame.

HEATER IS NOW INSTALLED, FOLLOW LIGHTING INSTRUCTIONS TO PLACE HEATER INTO SERVICE. FRONT PANEL MUST BE REMOVED FOR ACCESS TO LIGHTING INSTRUCTIONS AND GAS CONTROL.

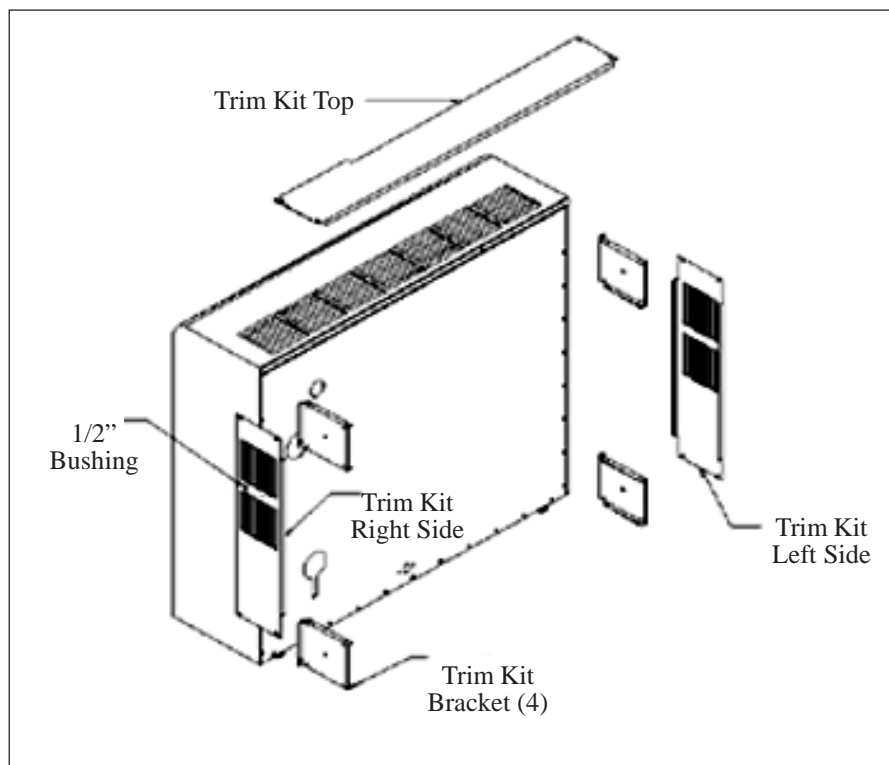

FIGURE 9

FOR YOUR SAFETY READ BEFORE OPERATING

WARNING: If you do not follow these instructions exactly, a fire or explosion may result causing property damage, personal injury or loss of life.

- A. This appliance does not have a pilot. It is equipped with an ignition device which automatically lights the burner. Do not try to light the burner by hand.
- B. BEFORE OPERATING smell all around the appliance area for gas. Be sure to smell next to the floor because some gas is heavier than air and will settle on the floor.
- WHAT TO DO IF YOU SMELL GAS:
- Do not try to light any appliance.
 - Do not touch any electric switch; do not use any phone in your building.
 - Immediately call your gas supplier from a neighbor's phone. Follow the gas supplier's instructions.
- If you cannot reach your gas supplier, call the fire department.
- C. Use only your hand to push in or turn the gas control knob. Never use tools. If the knob will not push in or turn by hand, don't try to repair it, call a qualified service technician. Force or attempted repair may result in a fire or explosion.
- D. Do not use this appliance if any part has been under water. Immediately call a qualified service technician to inspect the appliance and to replace any part of the control system and any gas control which has been under water.

OPERATING INSTRUCTIONS

1. STOP! Read safety information on this label.
2. Set the thermostat to the lowest setting.
3. Turn off all electric power to the appliance.
4. This appliance is equipped with an ignition device which automatically lights the burner. Do not try to light the burner by hand.
5. Remove cabinet to access gas control knob.
6. Turn gas control knob clockwise ↻ to "off". Do not force.
7. Wait five (5) minutes to clear out any gas. If you smell gas, STOP! Follow "B" in safety information on this label. If you don't smell gas, go to next step.
8. Turn gas control knob counterclockwise ↻ to "ON".
9. Turn on all electric power to the appliance.
10. Set thermostat to desired setting.
11. If the appliance does not operate, follow instructions "To Turn Off Gas To Appliance" and call your service technician or gas supplier.
12. Replace cabinet.

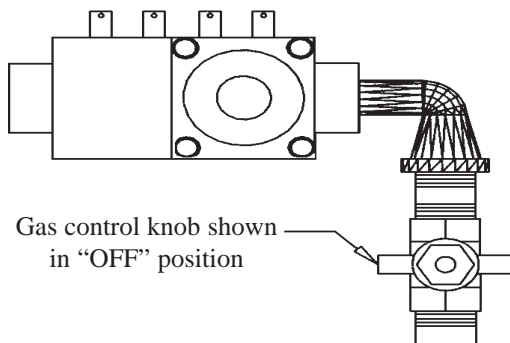

TO TURN OFF GAS TO APPLIANCE

1. Set the thermostat to lowest setting.
2. Turn off all electric power to the appliance if service is to be performed.
3. Turn gas control knob clockwise ↻ to "OFF". Do not force.

PROPER BURNER FLAME

The burner flame may be observed by raising the sight glass cover. A proper flame will have a dark blue inner mantle, with a lighter blue outer mantle that extends from the burner into the heat exchanger tube, (see Figure 10). There is no primary air adjustment on the burner, and proper flame is assured since the correct manifold pressure and orificing have been done at the factory.

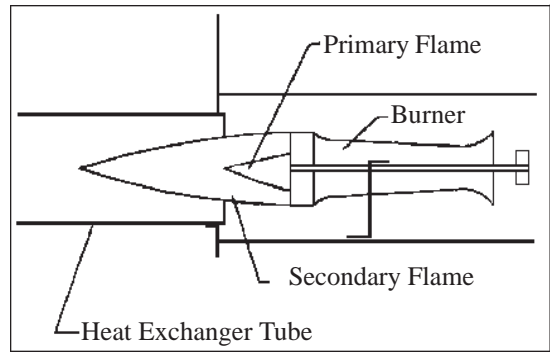

FIGURE 10

TO REMOVE MAIN BURNER FOR INSPECTION AND CLEANING

1. Turn off all electrical supply to heater.
2. Turn off gas supply.
3. Remove front panel.
4. Unplug wire to direct spark ignitor and sensor. (See Fig. 11.)
5. Disconnect vacuum hose from burner box.
6. Remove screws holding burner box top to burner box. (See Figure 11.)
7. Remove burner plate and burner box top. Take care not to contact, or strain ignitor in any way as it is extremely fragile. (See Figure 11.)
8. Remove 2 nuts holding burner bracket. (See Figure 11.)
9. Slide burners toward heat exchanger and lift up from rear and back. (See Figure 11.)
10. Clean or replace as needed.
11. Reinstall by reversing Steps 9 - 1.

BURNER ORIFICE

This appliance equipped only for altitudes 0 - 2,000 ft. Appliance input ratings are based on sea level operation and need not be changed for operation up to 2,000 feet (609.9 m) elevation. For operation at elevations above 2,000 feet (609.9 m).

The BTU input must be reduced 4% per 1,000 ft. Orifice change must be completed by a qualified installer or service technician. See the following orifice chart for the proper orifice drill size for a specific elevation.

SPECIFIC ELEVATIONS

MODEL NO.	0 to 2,000'	2,000' 4,000'	4,000' 6,000'	6,000' 8,000'	8,000' - 10,000'
<u>NATURAL GAS</u>					
HEDV253A	51	52	53	54	54
HEDV403A	45	47	48	49	50
<u>L.P. GAS</u>					
HEDV254A	58	60	62	63	64
HEDV404A	55	55	56	56	57

NOTE: THE FURNACE AND ALL COMPONENTS MUST BE INSPECTED AT LEAST ANNUALLY BY A QUALIFIED SERVICE TECHNICIAN. THIS SHOULD INCLUDE THE BURNER, HEAT EXCHANGER, AND VENT SYSTEM. BE SURE THAT THE FLOW OF COMBUSTION AND VENTILATION AIR ARE NOT OBSTRUCTED AND THAT ALL HOSES ARE UNDAMAGED, AND ALL CLAMPS ARE SECURELY TIGHTENED.

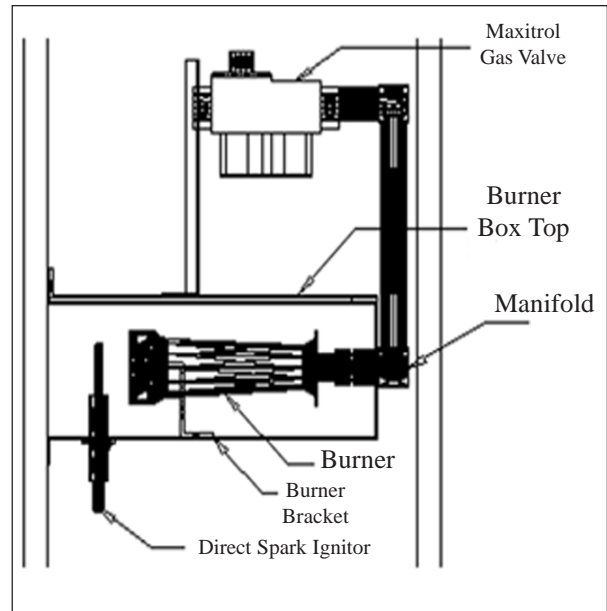

FIGURE 11

WIRING

This appliance is equipped with a three prong power cord with grounding plug. For your protection against shock hazard, this appliance should be plugged directly into a properly grounded three-prong receptacle. Do not cut or remove the grounding prong from this plug.

NOTE: If any of the original wire supplied with this appliance has to be replaced, it must be replaced with type 105°C wire or its equivalent.

CAUTION: Label all wires prior to disconnection when servicing controls. Wiring errors can cause improper and dangerous operation.

Verify proper operation after servicing.

WARNING

THIS IS A GAS-FIRED APPLIANCE. KEEP THE AREA CLEAR OF GASOLINE AND OTHER FLAMMABLE VAPORS AND LIQUIDS. ALL COMBUSTIBLE MATERIAL MUST BE KEPT CLEAR OF THIS AREA TO AVOID FIRE OR EXPLOSION.

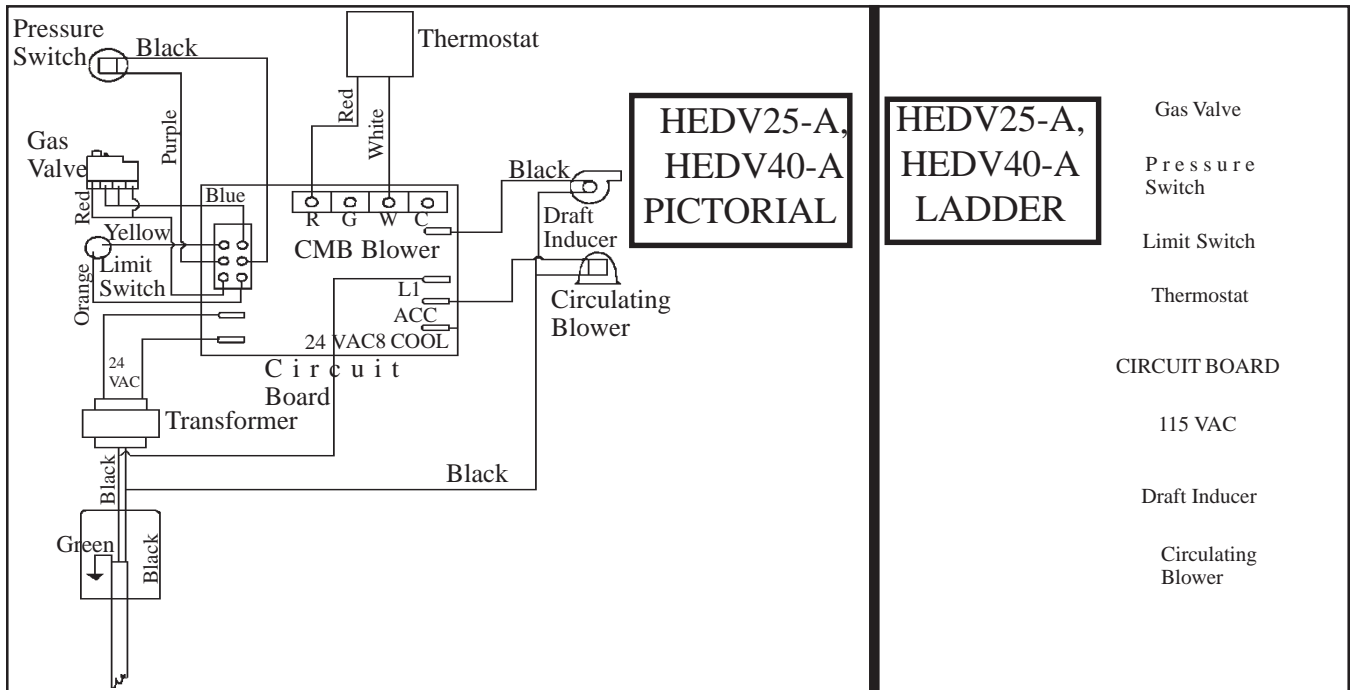

**HEDV253A, HEDV254A, HEDV403A, & HEDV404A
WIRING DIAGRAM**

HEDV SEQUENCE OF OPERATION

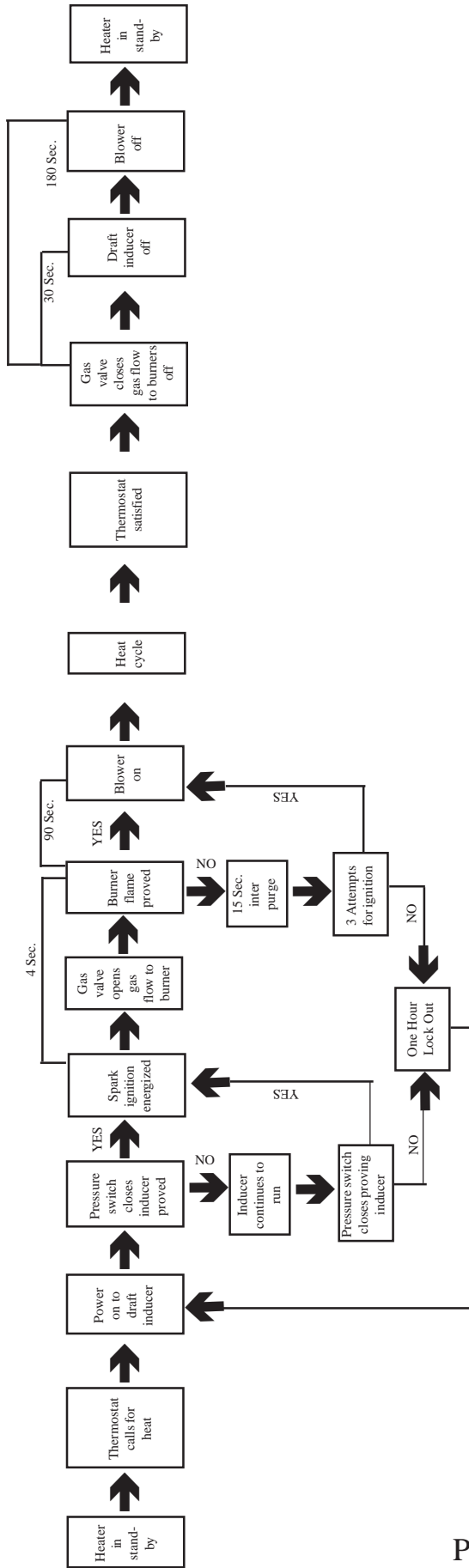

STEP #

- 1) Thermostat calls for heat.
- 2) Draft Inducer turns on.
- 3) Pressure switch closes.
- 4) Spark ignition begins.
- 5) Gas flow to burner.
- 6) Burner ignition proven.
- 7) Circulating Blower on.
- 8) Heater burns through heating cycle.
- 9) Thermostat satisfied.
- 10) Gas flow off to burner.
- 11) Draft inducer off.
- 12) Circulating Blowers off.
- 13) Heater in stand-by.

NOTE: IF THERE IS A MALFUNCTION IN STEPS 3, 5, 6 THE OPERATION SEQUENCE WILL STOP AT THAT POINT. FOR STEPS 5 OR 6, IF AFTER 2 ADDITIONAL ATTEMPTS MALFUNCTION STILL OCCURS, THE CONTROL WILL LOCK OUT FOR ONE HOUR. FOR PURPOSE OF TESTING, THE ONE HOUR LOCKOUT CAN BE OVERRIDDEN BY RESETTING THE THERMOSTAT OR INTERRUPTING THE ELECTRICAL POWER.

HEVK-5 5' VENT EXHAUST KIT INSTALLATION INSTRUCTIONS

WARNING: Use only Louisville Tin & Stove Company factory supplied parts and kits. Failure to do so could result in loss of life, personal injury, property damage, or unsatisfactory performance. This kit must be installed by a qualified installer or service technician.

CONTENTS OF KIT

1 only P/N 72532 2"x3" Steel Coupling	1 only P/N 41520 Center Bracket
1 only P/N 72575 2"x5' Black Flocked Tube	8 only P/N 72593 2" Hose Clamps
1 only P/N 72612 2"x6' Black Flex Tubing	1 only P/N 72578 2"x3" Black Silicone Wrapped Coupling
2 only P/N 41515 Support Brackets	

STEP 1 - LOCATE VENT OPENING

- a) Select location on outside wall that vent will exit through.
- b) Check outside for proper clearances around vent cap. See installation instructions.
- c) Mark and cut 3-1/2" hole through both inside and outside walls, being sure to maintain level across both openings.
- d) Measure wall thickness. Mark and cut off both intake and exhaust pipes to 1/2" beyond outside wall.
- e) Secure collection box to wall. Wall anchors, not provided, may be required.

STEP 2 - INSTALL HEATER

- a) Select location on wall where heater will be installed.
- b) Using wall template supplied with heater, mark location for trim kit wall brackets.
- c) Attach brackets to wall (wall anchors, not provided may be required) and back of heater. Using screws provided on back of heater.
- d) Slide heater into position and secure brackets together. This should position back of heater 5" off wall.
- e) Select direction vent will exit trim kit, left, right, or straight up.
- f) Before installing trim kit remove knockout on this side.

STEP 3 - INSTALL VENT

- a) Remove and discard P/N 72611 2"x24" black flex tubing from air inlet. (Save hose clamp).
- b) Attach P/N 72612 2"x6' black flex tubing to air inlet. Secure with P/N 72593 2" hose clamp.
- c) Slide P/N 72575 2"x5' flocked tube through trim kit opening (knockout) and attach to P/N 72610 orange silicone 90E elbow supplied with heater. Secure with 2" hose clamp.
- d) Attach P/N 41515 support brackets to wall. Wall anchors, not provided, may be required. Position support brackets within 8" from side of trim kit and end of pipe. Secure flex tubing and flocked tube to brackets using 2" hose clamps.
- e) Attach P/N 41520 center bracket 2-1/2' from pipe end and insert flex tube through bracket. This will prevent the flex tube from touching the black flocked exhaust tube.
- f) Connect flex air intake tube and flocked exhaust tube to collection box.
- g) Complete gas connection and attach trim kit to brackets.
- h) Follow lighting instructions.

SPECIAL NOTES

- a) You may use up to three HEVK-5 Kits for a total of 15' vent extension with two additional elbows. **DO NOT EXTEND VENT BEYOND 15' OR USE MORE THAN THREE TOTAL ELBOWS (one elbow comes with the heater).**
- b) To connect two vent kits together use P/N 72532 2"x3" steel coupling. Secure with 2" hose clamps.
- c) If you are using one, two, or three kits, after installation is complete you will discard 2 P/N 72593 hose clamps and one P/N 72532 steel coupling.
- d) If you need to make a 90E offset you will need to order P/N HEEL-1 90E Elbow Kit. Two offsets require two kits.
- e) If complete vent extension is horizontal, pipes may be sloped down slightly to allow any condensate to drain through the exhaust pipe to the outside. **DO NOT ALLOW TO DRAIN ONTO WALKWAY.** If any part of vent extension is vertical or local codes do not allow draining of condensate to outside you must add P/N 18900 Condensate Kit.
- f) For cosmetic purposes, the addition of the HEVK-5 Kit can be enclosed by adding a HEVE-5 Vent Enclosure Kit. To completely enclose the HEVK-5 Kit one HEVE-5 will be needed for each HEVK-5 used.

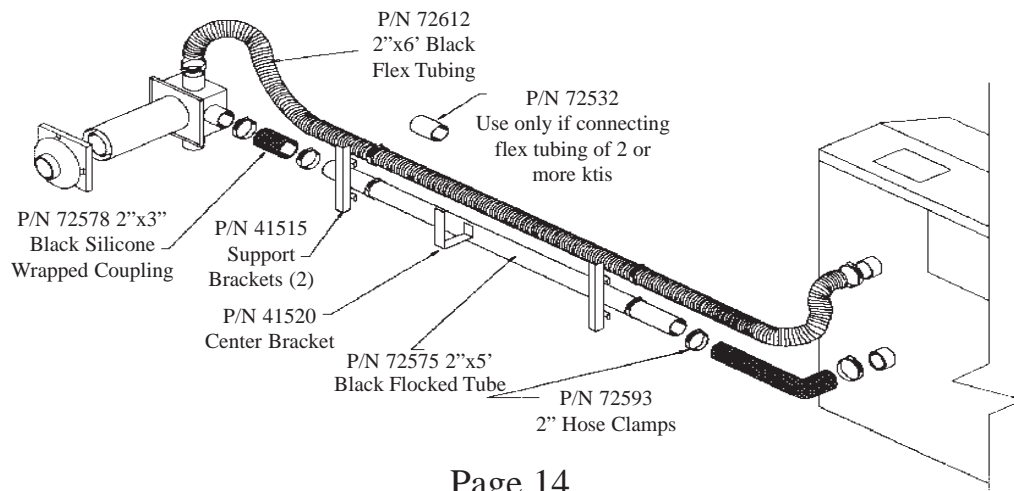

**HEVE-5
VENT ENCLOSURE KIT
INSTALLATION INSTRUCTIONS**

This kit must be installed by a qualified installer or service technician.

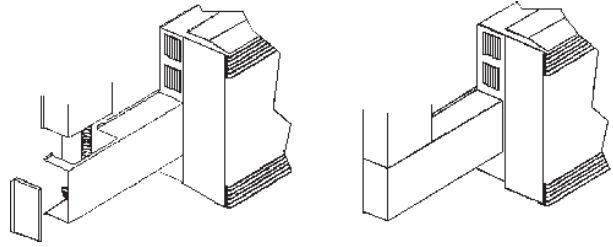

STEP 1) Position end of Part No. 41610 enclosure body to heater trim kit where pipes exit trim kit, centering pipes inside body and attach to wall. Wall anchors, not provided, may be required. Collector box may be behind HEVE-5 Kit.

STEP 2) Cut to fit enclosure panel 1" beyond end of vent run. Insert Part No. 41620 End Cap and attach using three #8 screws provided.

SPECIAL INSTRUCTIONS

STEP 3) If more than one HEVE-5 Kit is used, attach Part No. 72604 Trim Kit where ends meet.

STEP 4) If making a 90° turn, measure 1" beyond outside turn and cut off enclosure panel. Notch panel on surface of direction turn is being made to allow pipes to pass through into next HEVE-5 Kit. Attach second panel to wall and attach Part No. 72604 Trim Kit where two bodies meet. Install end cap Part No. 41620.

**HEEL-1
90° ELBOW KIT**

Contains 1 only P/N 72613 90° Elbow 2"

18900 CONDENSATE KIT

INSTRUCTIONS

HI-EFFICIENT DIRECT-VENT WALL FURNACE

Always use this kit when the vent has a vertical run, or where local codes prohibit draining condensate to the outside. Use only Cozy Heating Systems supplied parts. Failure to use factory supplied parts or to follow these instructions may result in unsatisfactory performance, property damage, personal injury and/or loss of life.

Before beginning kit installation, open carton and identify the following components.

- A) P/N 18910 Condensate Pan Assembly
- B) P/N 72618 Condensate Trap Assembly
- C) P/N 72538 3/8" Tubing
- D) P/N 72539 3/8" Hose Clamp (2)
- E) P/N 50606 #8 x 1/2" screws (2)

Step 1. Set thermostat to "off" and allow heater to cool.

Step 2. Turn off gas supply to heater.

Step 3. Turn off electric power to heater.

Step 4. Remove the cabinet.

Step 5. Loosen the two wing nuts located in the heater base. See Figure 1.

Step 6. Slide the condensate pan into the bottom of the heater with slots in tabs onto the weld studs and under the wing nuts. Use care to not rip the insulation in bottom of heater. Tighten the wing nuts to secure condensate pan. See Figure 1.

Step 7. Remove and discard the button plug located at center lower area of heater back.

Step 8. Attach condensate trap to heater back so bottom of trap is inside the bottom of the condensate pan. Secure using the (2) #8 screws provided. Fill trap with water. See Figure 2.

Step 9. Remove and discard plastic cap from bottom of the draft inducer drain tube. See Figure 2.

Step 10. Connect the tubing to the draft inducer drain tube and the condensate trap. Secure both ends with two 3/8" hose clamps provided. See Figure 2.

Step 11. Fill the condensate pan with water.

Step 12. Reverse steps 4 – 1. Follow lighting instructions to place heater in operation.

WARNING: The water level in the condensate pan must be checked and maintained to completely cover the condensate trap. The water provides a seal to prevent combustion products from coming through the condensate trap and entering the living area.

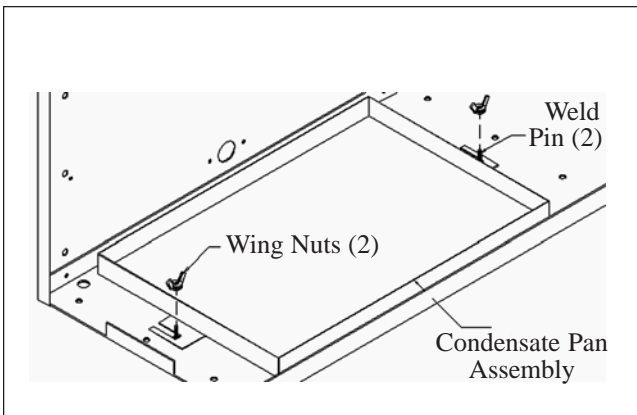

FIGURE 1

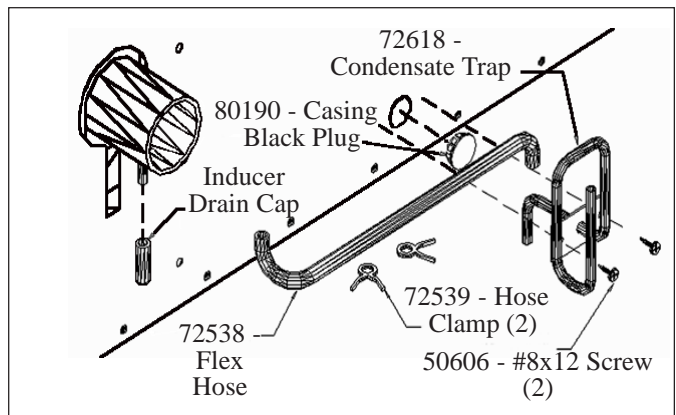

FIGURE 2

MAINTENANCE INSTRUCTIONS

For proper and safe operation keep furnace and furnace area clean. At regular intervals turn control valve to off, let cool and clean inside control and heat exchanger compartment. To clean front panel use only a damp cloth, do not use any kind of solvent or cleaning fluid that could leave a residue to burn or give off fumes when furnace is turned on.

Have the furnace checked, cleaned, and repaired by a qualified service technician. Check venting system, and burner operation prior to use each year.

Follow a regular service and maintenance schedule for safe and efficient operation.

Do not obstruct combustion and ventilation air. Examine the venting system as a routine part of the safety performance check on an annual basis.

If the heat exchanger is removed, check the heat exchanger intake gasket and draft inducer gasket and replace if there is any sign of damage. Be sure all gaskets are in place when the heat exchanger is replaced.

Failure to replace any gasket that has been damaged may result in property damage, personal injury or loss of life. Oil the bearings of the fan motor every 6 months with S.A.E. 20 oil.

SERVICE RECORD

TROUBLE SHOOTING CHART - For use by a qualified service technician.

SYMPTOM	POSSIBLE CAUSES	CORRECTIVE ACTION To be taken by Contractor
Flame too large	<ol style="list-style-type: none"> 1. Defective operator section of valve. 2. Burner orifice too large. 3. If installed above 2,000 ft. 	<ol style="list-style-type: none"> 1. Replace valve. 2. Check with local gas company for proper orifice - size and replace. 3. See burner orifice section, Page 11.
Yellow burner flame	<ol style="list-style-type: none"> 1. Clogged burner ports. 2. Obstruction around vent cap. 	<ol style="list-style-type: none"> 1. Remove burners and check for obstructions in throats, ports, and orifices. Clean - but do not enlarge ports or orifices. 2. Make sure area around vent cap is clear, be sure vent system is sealed.
Gas odor	<ol style="list-style-type: none"> 1. Gas leak. 	<ol style="list-style-type: none"> 1. See Page 1.
Delayed Ignition	<ol style="list-style-type: none"> 1. Low gas pressure. 2. Igniter not properly located. 	<ol style="list-style-type: none"> 1. Check gas supply pressure. 2. Check ignitor location and correct if necessary.
Failure to ignite	<ol style="list-style-type: none"> 1. Main gas off. 2. Thermostat not set high enough to call for heat. 3. Clogged burner orifice. 4. Incorrect wiring. 5. Defective valve. 6. No power to unit. 	<ol style="list-style-type: none"> 1. Open manual gas valve. 2. Set thermostat to higher temperature. 3. Clean burner orifices (do not enlarge). 4. Check wiring diagram. 5. Replace valve. 6. Plug in power supply cord. Check 115 V. wall outlet.
Burner won't turn off	<ol style="list-style-type: none"> 1. Defective or damaged thermostat wire, or thermostat. 2. Thermostat location. 3. Defective or sticking valve. 4. Excessive gas pressure. 5. Defective or damaged thermostat. 	<ol style="list-style-type: none"> 1. Can be checked by removing wire from control board terminal. If burner goes off, replace thermostat. 2. Re-locate out of drafts, hot, or cold spots. 3. Replace valve. 4. Contact utility supplying gas. 5. Replace thermostat.
Incorrect gas input	<ol style="list-style-type: none"> 1. Gas input not checked. 2. Clogged orifices. 	<ol style="list-style-type: none"> 1. Re-check gas input. 2. Clean orifices with a smooth wood toothpick, do not enlarge.
Not enough heat	<ol style="list-style-type: none"> 1. Furnace undersized. 2. Thermostat temperature set too low. 3. Incorrect supply pressure. 	<ol style="list-style-type: none"> 1. This is especially true when a dwelling or room is enlarged. Have the heat loss calculated and compare to furnace output. Your gas company can supply you with this information. If furnace is undersized, replace with correct size unit. 2. Raise thermostat temperature setting. 3. Check supply pressure.
Too much heat	<ol style="list-style-type: none"> 1. Temperature set too high. 2. Combination control valve stuck open. 	<ol style="list-style-type: none"> 1. Lower temperature setting. 2. Replace combination control valve.
Main burner goes out during normal operation	<ol style="list-style-type: none"> 1. Defective flame sensor. 2. Input too high. 3. Sight glass not air tight. 4. Vent tubes not properly installed or sealed. 5. Limit switch opens. 6. Exhaust or Air Intake tubes blocked. 	<ol style="list-style-type: none"> 1. Check voltage and replace if low. 2. Check input rate. 3. Tighten screws securing sight glass. Check and replace gasket if needed. 4. Follow instructions. Check both exhaust and air intake tubes, and vent cap. Be sure all gaskets are in place and properly sealed. Use only tubes and vent cap supplied. Do not alter vent tubes or cap. 5. Check for blockage of discharge air. 6. Check for and remove any obstruction to incoming circulating air.

TROUBLE SHOOTING CHART - for use by a qualified service technician.

To assist in diagnosing and servicing, this heater is equipped with a self-diagnosing control module. Should a malfunction occur, the green indicator light on the control module will flash a varying number of times indicating the circuit in which malfunction is located.

# OF FLASHES	REASON FOR INDICATION	POSSIBLE CAUSES	CORRECTIVE ACTION TO BE TAKEN BY CONTRACTOR
Slow Flash	Normal operation, no call for heat		
Fast Flash	Normal operation, call for heat		
2	System lockout failed to detect or sustain flame	<ul style="list-style-type: none"> a.) Defective ignitor. b.) Ignitor cable defective. c.) Ignitor cable disconnected. d.) Manual gas valve in "OFF" position. No gas to valve. e.) Defective wire to gas valve. f.) Wire to gas valve disconnected. g.) Obstruction to vent outlet. h.) Obstruction to air inlet. 	<ul style="list-style-type: none"> a.) Replace ignitor. b.) Replace ignitor cable. c.) Connect ignitor cable. d.) Turn manual gas valve to "ON". e.) Replace defective wire. f.) Connect gas valve wire. g.) Remove obstruction. h.) Remove obstruction.
3	Pressure switch Open or Closed	<ul style="list-style-type: none"> a.) Defective pressure switch. b.) Pressure switch tubing damaged, kinked or collapsed. c.) Pressure switch tubing disconnected. d.) Defective draft inducer. e.) Pressure switch tubing to wrong connection. 	<ul style="list-style-type: none"> a.) Replace pressure switch. b.) Replace damaged tubing. c.) Connect pressure switch tubing. d.) Replace draft inducer. e.) Reverse tubing connections on pressure switch.
4	Limit Switch opens	<ul style="list-style-type: none"> a.) Defective limit switch. b.) Damaged limit switch wire. c.) Limit switch wire disconnected. d.) Blockage in front of front panel. e.) Heater over rate. 	<ul style="list-style-type: none"> a.) Replace limit switch. b.) Replace damaged wire. c.) Connect limit switch wire. d.) Remove blockage. e.) Check orifice, pressures, rate.
5	Flame sensed gas valve not energized	<ul style="list-style-type: none"> a.) Defective gas valve. b.) Defective control module. 	<ul style="list-style-type: none"> a.) Replace gas valve. b.) Replace control module.
Steady light No Flashes	Internal failure (control module failure and power on self-check)	<ul style="list-style-type: none"> a.) Defective control module. 	<ul style="list-style-type: none"> a.) Replace control module.

MODEL NUMBERS

HEDV253A - NAT. GAS

HEDV403A - NAT. GAS

HEDV254A - L.P. GAS

HEDV404A - L.P. GAS

**HI-EFFICIENT DIRECT VENT
WALL FURNACE**

Prices and specifications subject
to change without notice.

All prices are F.O.B. factory.

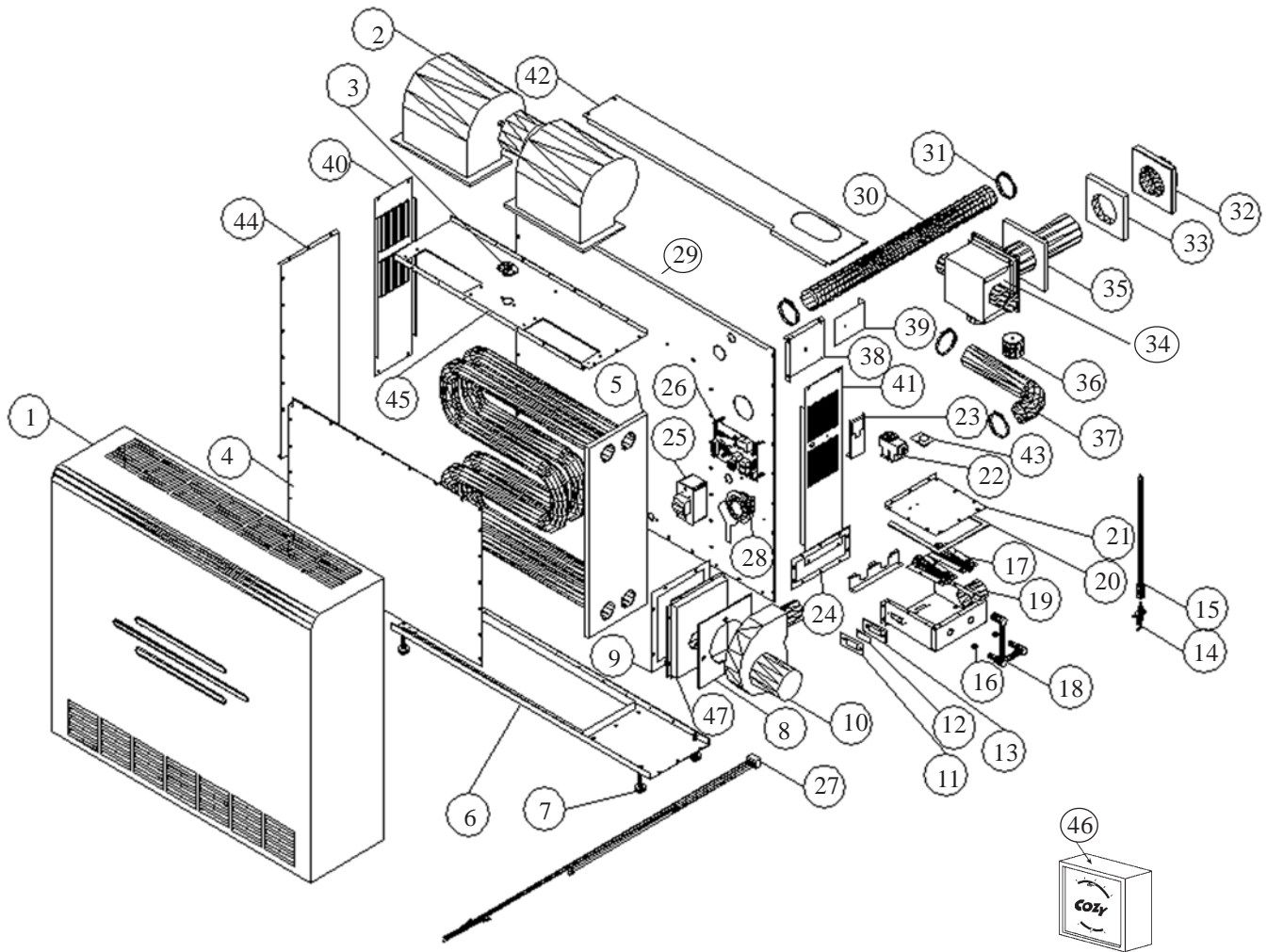

ATTN: CONTRACTORS AND SERVICE TECHNICIANS, we only sell parts through our wholesalers, but the prices listed are for your convenience. For prompt parts service, contact the wholesaler from which you purchased your Cozy heater. **NOTE:** Parts & schematic drawings on current models are shown at www.cozyheaters.com.

HOW TO PROPERLY ORDER PARTS: In addition to part description and part number, please give model number, serial number, and type of gas used. This information can be found on the rating plate that is attached to heater.

PART DESCRIPTION	REF. NO.	HEDV253A		HEDV254A		HEDV403A		HEDV404A	
		PART NO.	LIST PRICE	PART NO.	LIST PRICE	PART NO.	LIST PRICE	PART NO.	LIST PRICE
Cabinet	1	18020		18020		18520		18520	
Circulating Blower	2	72501		72501		72500		72500	
Limit Switch	3	72671		72671		72670		72670	
Front Heat Shield	4	18100		18100		18595		18595	
Tubular Heat Exchanger	5	72531		72531		72530		72530	
Cabinet Base Assembly	6	18120		18120		18620		18620	
Leg Leveler (4 Per)	7	80009		80009		80009		80009	
Draft Inducer Gasket - 7-3/4x9"	8	72565		72565		72565		72565	
Draft Inducer Mounting Plate Gasket	9	72563		72563		72563		72563	
Draft Inducer	10	72506		72506		72506		72506	
Sight Glass Frame	11	18185		18185		18185		18185	
Sight Glass	12	70150		70150		70150		70150	
Sight Glass Gasket - 2-5/8x1-3/8"	13	72564		72564		72564		72564	
Ignitor	14	64009		64009		64009		64009	
Ignitor Cable	15	64210		64210		64210		64210	
Burner Orifice (Requires 2)	16	*95251		*95258		*72156		*72139	
Burner	17	*72528		*72528		*72528		*72528	
Manifold	18	72640		72640		72640		72640	
Burner Box Assembly	19	18150		18150		18150		18150	
Burner Box Top Gasket - 6-3/4x6-1/2"	20	72567		72567		72567		72567	
Burner Box Top	21	18165		18165		18165		18165	
Gas Valve	22	64590		64591		64590		64591	
Gas Valve Support Bracket	23	18180		18180		18180		18180	
Burner Box Mounting Gasket - 7 ³ / ₄ x3 ¹ / ₂ "	24	72566		72566		72566		72566	
Transformer	25	78069		78069		78069		78069	
Circuit Board	26	64625		64625		64625		64625	
Wiring Harness	27	72675		72675		72675		72675	
Pressure Switch	28	72517		72517		72518		72518	
Casing Back	29	18090		18090		18590		18590	
Air Intake Hose	30	72611		72611		72611		72611	
2" Hose Clamp (4 Per)	31	72593		72593		72593		72593	
Vent Cap Assembly	32	18250		18250		18650		18650	
Vent Cap Gasket - 4-3/32x4-3/32"	33	72608		72608		72608		72608	
Collection Box Assembly	34	18225		18225		18225		18225	
Collection Box Gasket - 5-7/16x5-7/16"	35	72607		72607		72607		72607	
Collection Box Cap	36	72587		72587		72587		72587	
Vent Exhaust Tube	37	72610		72610		72610		72610	
Trim Kit Bracket (Requires 4)	38	18320		18320		18320		18320	
Wall Mounting Bracket (Requires 4)	39	18315		18315		18315		18315	
Trim Kit, Left Side Panel	40	18310		18310		18310		18310	
Trim Kit, Right Side Panel	41	18305		18305		18305		18305	
Trim Kit Top	42	18300		18300		18700		18700	
HEDV Wire Bracket	43	18190		18190		18190		18190	
Liner, Left Side	44	18110		18110		18610		18610	
Liner Top	45	18075		18075		N/A		N/A	
Wall Thermostat, 24 Volt	46	78355		78355		78355		78355	
Draft Inducer Mounting Plate	47	18200		18200		18200		18200	
Thermostat Wire 20'	N/A	74518		74518		74518		74518	
Power Cord	N/A	64205		64205		64205		64205	
Manual Shut-off Valve (Off-On)	N/A	64074		64074		64074		64074	
Condensate Kit	N/A	18900		18900		18900		18900	

ATTN: CONTRACTORS AND SERVICE TECHNICIANS, we only sell parts through our wholesalers, but the prices listed above are for your convenience. For prompt parts service, contact the wholesaler from which you purchased your Cozy heater. **NOTE:** Parts & schematic drawings on current models are shown at www.cozyheaters.com.

LIMITED WARRANTY

Cozy Heating Systems LLC warrants to the original user the accompanying product for the period specified herein, provided said product is installed, operated, maintained, serviced, and used according to the instructions and specifications accompanying the product. **AS OUTLINED IN OUR INSTRUCTIONS, ANY WARRANTY CONSIDERATIONS ARE CONTINGENT ON INSTALLATION BY A QUALIFIED INSTALLER (CONTRACTOR). SELF-INSTALLATION IS PROHIBITED AND WILL INVALIDATE YOUR WARRANTY.**

If within a period of one year from the date of installation of the product, any part supplied by the manufacturer proves to be defective due to workmanship or material, it will replace such part, provided parts have not been subjected to misuse, alteration, neglect, or accidents. The term of the warranty for the heat exchanger and burners is covered in Table A below. Any claim not made within ten (10) days after the expiration of the warranty period shall be deemed waived by the user.

The manufacturer shall have no liability or be required to perform any obligation under this warranty unless, when requested, the user returns, at the user's expense, the component or product claimed defective, to the manufacturer for inspection, to enable the manufacturer to determine if the claimed defect is covered by this warranty.

No charges for freight, labor or other expenses incurred in the repair, removal, or replacement of any product or component claimed to be defective, will be paid by the manufacturer to the user, and the manufacturer will not be liable for any expenses incurred, by the user, in remedying any defect in the product.

Service under this warranty is the responsibility of the installer. In the event service

under this warranty is needed, the user of the product shall request such service directly from the installer. If the user is unable to locate the installer, the user should write directly to the manufacturer, and the name of an alternative service source will be supplied.

The product safety registration card (packed inside the appliance) must be completed and returned to the factory.

THIS WARRANTY IS EXPRESSLY IN LIEU OF ANY OTHER WARRANTIES, EXPRESS OR IMPLIED (WHETHER WRITTEN OR ORAL). ANY IMPLIED WARRANTY OF MERCHANTABILITY OR OF FITNESS FOR A PARTICULAR PURPOSE IS EXPRESSLY LIMITED TO THE DURATION OF THE MANUFACTURER'S EXPRESS, WRITTEN WARRANTY.

UNDER NO CIRCUMSTANCES SHALL THE MANUFACTURER BE LIABLE FOR ANY SPECIAL, INDIRECT OR CONSEQUENTIAL DAMAGES OR EXPENSES ARISING DIRECTLY OR INDIRECTLY FROM ANY COMPONENT OR FROM THE USE THEREOF. THE REMEDIES SET FORTH HEREIN SHALL BE THE EXCLUSIVE REMEDIES AVAILABLE TO THE USER AND ARE IN LIEU OF ALL OTHER REMEDIES.

SOME STATES DO NOT ALLOW LIMITATIONS ON HOW LONG AN IMPLIED WARRANTY LASTS, SO THE ABOVE LIMITATIONS MAY NOT APPLY TO YOU.

SOME STATES DO NOT ALLOW THE EXCLUSION OR LIMITATION OF INCIDENTAL OR CONSEQUENTIAL DAMAGES, SO THE ABOVE LIMITATIONS OR EXCLUSIONS MAY NOT APPLY TO YOU.

THIS WARRANTY GIVES YOU SPECIFIC LEGAL RIGHTS, AND YOU MAY ALSO HAVE OTHER RIGHTS, WHICH VARY, FROM STATE TO STATE.

TABLE A

<u>Product</u>	<u>Warranty Period</u>	
	<u>Heat Exchanger/Tubes</u>	<u>Burners</u>
Cozy Gas Fired Floor Furnace	10 Years	10 Years
Cozy Gas Fired Wall Furnace	10 Years	10 Years
Cozy Gas Fired Vented Console Heater	10 Years	10 Years
Cozy Gas Fired Direct Vent Heater	10 Years	10 Years
Cozy Gas Fired Counterflow Furnace	10 Years	10 Years
Cozy Gas Fired Counterflow Direct Vent Furnace	10 Years	10 Years
Cozy Gas Fired Mobile Home Direct Vent Furnace	10 Years	10 Years
Cozy Gas Fired Hi-Efficient Direct Vent Wall Furnace	10 Years	10 Years
Cozy Gas Fired Direct Vent Baseboard Heater	10 Years	10 Years
Cozy Fan-Type, Direct Vent Through-The-Wall Gas Heater	10 Years	10 Years
Cozy Blue Flame Vent Free Heater	N/A	10 Years
Cozy Infra-Red Vent Free Heater	N/A	N/A

COZY HEATING SYSTEMS LLC

3230 INDUSTRIAL PARKWAY. – JEFFERSONVILLE, IN 47130