

Installation manual

Concentric Vent / Air Intake Kit Stainless Steel

For Bosch Models: GWH 715 ES, GWH 2400 ES, GWH 2700 ES, Evolution 500

Part Number: ESHCK



BOSCH

Invented for life

Table of Contents

1	Introduction	4
1.1	Items included with Concentric vent kit	4
1.2	Venting material compatibility	4

2	Installation	5
---	--------------	---

1 Introduction



CAUTION:
The following is not a substitute for the tankless water heater installation manual. The entire installation must conform with the specifications listed in the tankless water heater installation manual.

The following stainless concentric vent kit is designed to provide one penetration point through the exterior wall for both combustion air and exhaust vent piping. This kit is only for horizontal sidewall terminations. It is not approved for through the roof, vertical terminations. The stainless concentric vent kit is compatible with the following Bosch tankless water heaters:

- GWH 2400 ES
- GWH 2700 ES
- GWH 715 ES
- Evolution 500

1.1 Items included with Concentric Vent kit:

See Figure 1

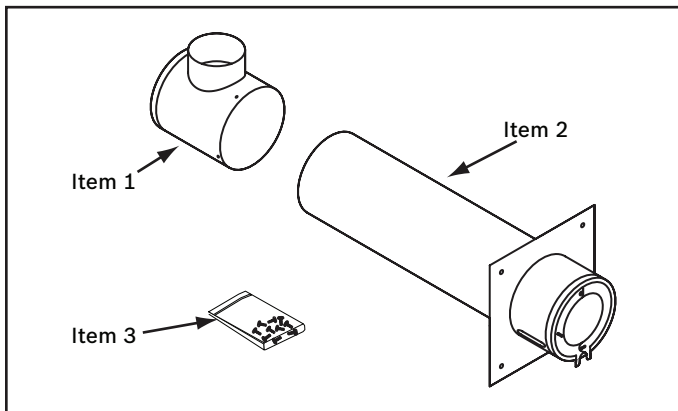

Fig. 1 Concentric vent kit components

- Item 1 - intake pipe connector
- Item 2 - exterior wall chase
- Item 3 - bag of screws

This kit can be ordered from your local supplier (part# ESHCK).

1.2 Venting material compatibility

The exhaust vent piping used with this kit must be 3" sealed single wall stainless steel (AL29-4C). The combustion air piping used with this kit must be 3" sealed PVC or any other rigid pipe.



Only tee terminals are approved for use with the concentric vent / air intake kit (see Table 1).

Approved terminals	Manufacturer part numbers		
	Z-flex	Protech	Heat Fab
3" Tee Terminal	2SVSTTF03	FSTT3	9390TEE

Table 1 Approved Tee Terminals



The exhaust vent piping and tee terminal used with the kit must be from the same vent pipe manufacturer.

1.3 Concentric Vent kit dimensions

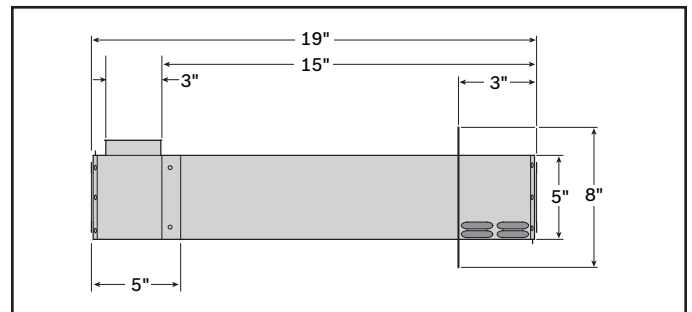

Fig. 2 Concentric Vent kit dimensions

2 Installation

1. Ensure all items listed in Section 1.1 are complete.
2. Common installation practice is to determine the termination and exterior wall penetration point first. Next, design the venting/intake piping layout back to the heater. Keep in mind, centrally locating the water heater, whenever possible, is recommended to keep hot water distribution times even throughout the structure.
3. To determine the appropriate penetration point, refer to the allowable termination clearances listed in Figure 7.
4. Once penetration point is determined, use a 5" hole saw with proper blade (depending on wall construction) to cut hole for kit installation.
5. Insert Item 2 (Fig. 1) through exterior wall from the outside until flange is flush with wall surface. Ensure that combustion air openings on Item 2 face toward the ground as shown in Fig. 6. Secure flange to exterior wall with screws provided.
6. Connect item 1 to item 2 (Fig. 1) from inside the structure. The air intake connection opening (Item 1) can be turned to best suit the connection of the intake pipe. Secure both items with machine screws provided.
7. Locate end clamps on concentric kit (Fig. 3, step 1). Open clamps as shown in Figure 3, step 2.

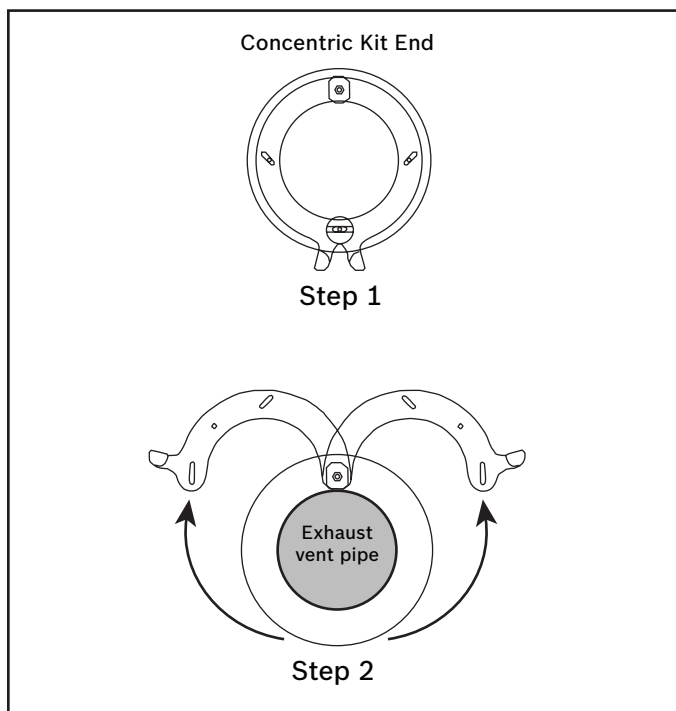

Fig. 3 Concentric end clamps

8. Insert vent piping through the concentric vent kit. Close end clamps around vent pipe (Fig. 4, step 3). Secure clamps by inserting screws where shown (Fig. 4, step 4).

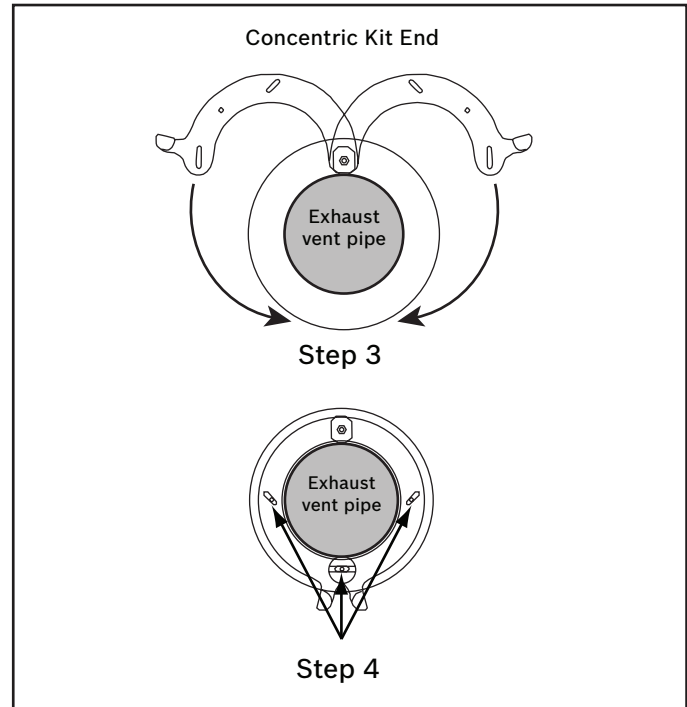

Fig. 4 Securing vent piping with clamps

9. On the outside of the structure, connect tee terminal to exhaust vent pipe (Fig. 5). Be sure to maintain 12" clearance from exterior wall to tee terminal as indicated in Figure 6.

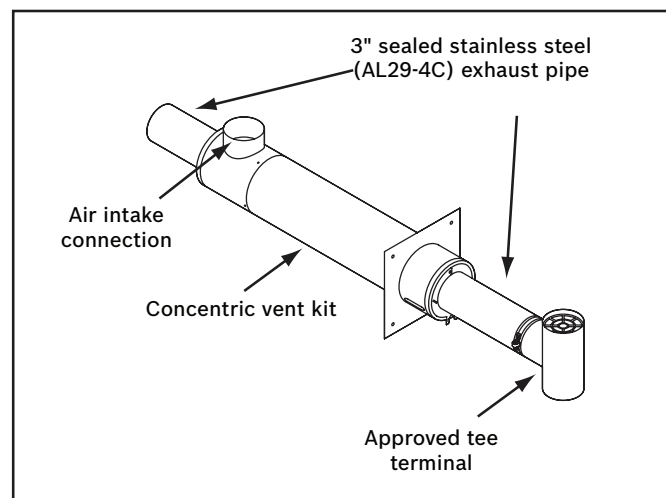

Fig. 5 Concentric vent assembly

10. Connect combustion air piping to air intake connection on concentric vent kit (Fig. 5). Secure with machine screws.

10. Finish exhaust vent and combustion air piping installation back to the water heater.
11. Complete tankless water heater installation per the water heater's installation manual (Fig. 6).

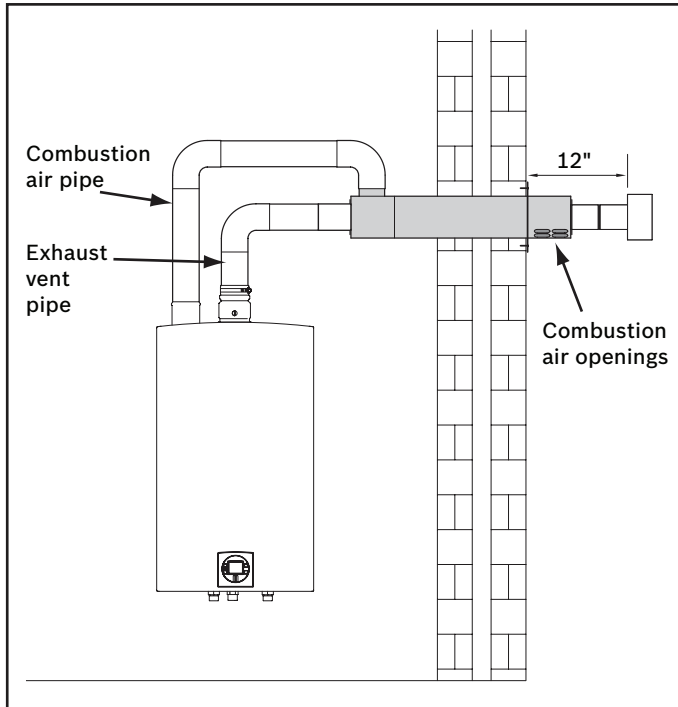
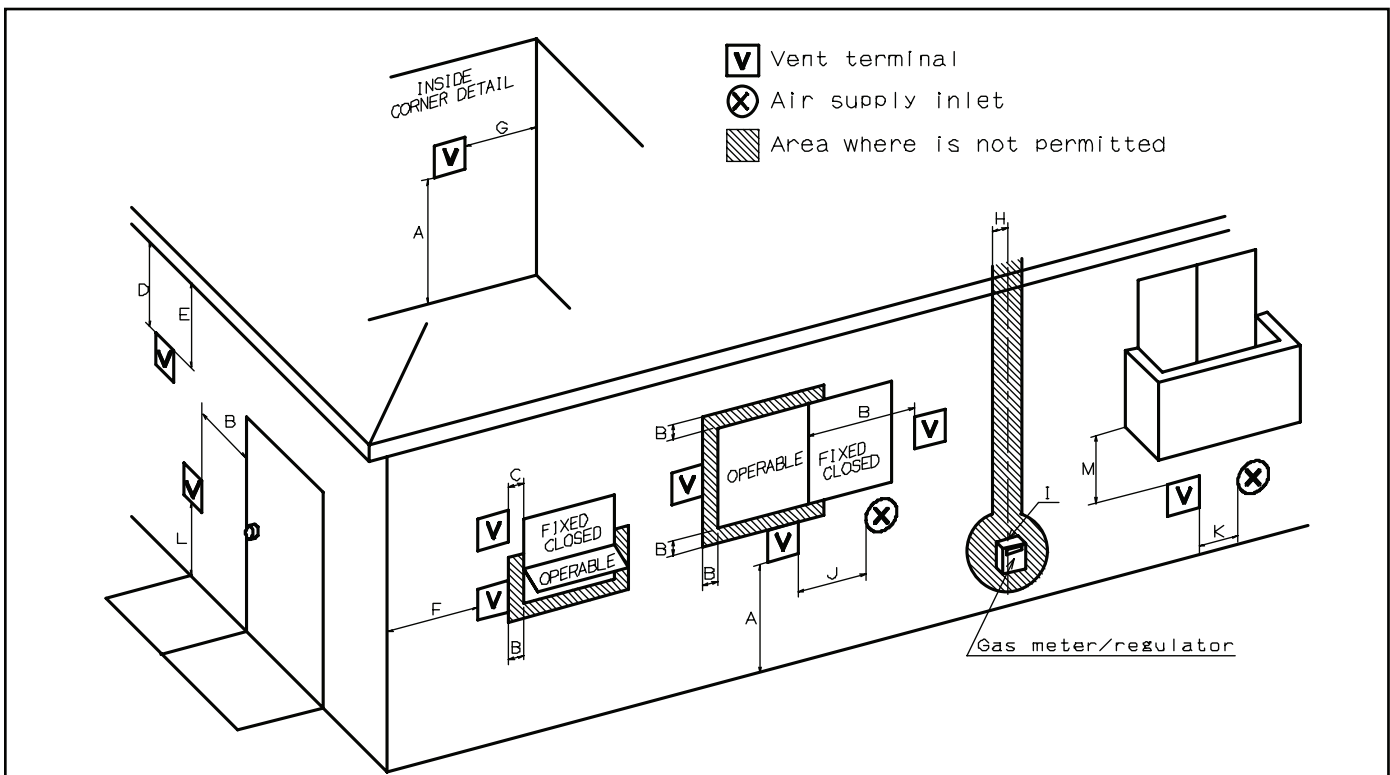

Fig. 6 Completed concentric vent kit installation



		Canadian installations ¹⁾	U.S. installations ²⁾
A	Clearance above grade, veranda, porch, deck or balcony	12 in.	12 in.
B	Clearance to window or door that may be opened	36 in.	12 in.
C	Clearance to permanently closed window	*	*
D	Vertical clearance to ventilated soffit located above the vent terminator within a horizontal distance of 2 feet (61cm) from the center line of the terminator	*	*
E	Clearance to unventilated soffit	*	*
F	Clearance to outside corner	*	*
G	Clearance to inside corner	*	*
H	Clearance to each side of center line extended above meter/regulator assembly	36 in. within a height 15 feet above meter/ regulator assembly	*
I	Clearance to service regulator vent outlet	36 in.	*
J	Clearance to non-mechanical air supply inlet to building or the combustion air inlet to any other application	36 in.	12 in.
K	Clearance to mechanical air supply inlet	72 in.	36 in. above if within 10 feet horizontally
L	Clearance above paved sidewalk or paved driveway located on public property	84 in. ³⁾	*
M	Clearance under veranda, porch deck or balcony	12 in. ⁴⁾	*

1) In accordance with the current CSA B149.1 Natural Gas and Propane Installation Code
 2) In accordance with the current ANSI Z223.1 / NFPA 54 National Fuel Gas Code
 3) A vent shall not terminate directly above a sidewalk or paved driveway that is located between two single family dwellings and serves both dwellings. Permitted only if veranda, porch, deck or balcony is fully open on a minimum of two sides beneath the floor.
 4) For clearances not specified in ANSI Z223.1 / NFPA54 or CSA-B149.1, one of the following shall be indicated:
 a) A minimum clearance value determined by testing in accordance with section 2.20, or;
 b) A reference to the following footnote:
 "Clearance in accordance with local installation codes and the requirements of the gas supplier."

Fig. 7 Required direct vent terminal clearances (twin pipe / concentric penetration)

Bosch Thermotechnology Corporation
50 Wentworth Avenue
Londonderry, NH 03053
Tel.: 800-642-3111
Fax: 603-584-1681
www.boschhotwater.com

BTC 710003302 A

Bosch Thermotechnology Corporation reserves the right to make changes without notice due to continuing engineering and technological advances.



BOSCH