

C 950 ES Gas Condensing Water Heater

Engineering Submittal Sheet

C 950 ES Performance Data

Maximum Gas Input (BTU)	175,000
Minimum Input (BTU)	19,900
Maximum Output (BTU)	163,900
Minimum Output (BTU)	19,600
Thermal Efficiency	93%
Energy Factor	0.92

C 950 ES Operational Data

Weight (lbs.)	74
Min. Inlet Gas Pressure NG("WC) / LP("WC)	3.5 / 8
Max. Inlet Gas Pressure NG("WC) / LP("WC)	10.5 / 13
C950ES Maximum Output Temperature (°F)	140°F
Flow Rate at 35°F ΔT (GPM)	9.2
Flow Rate at 45°F ΔT (GPM)	7.2
Flow Rate at 50°F ΔT (GPM)	6.4
Flow Rate at 60°F ΔT (GPM)	5.4
Max. Working Pressure (psi)	150
Min. Working Pressure (psi)	30
Min. Activation Flow (GPM)	0.5
Relief Valve Pressure Rating (psi)	150

C 950 ES Approved Venting Material

Item	Material	United States	Canada
Vent or air pipe and fitting	PVC schedule 40	ANSI/ASTM D1785	CSA or ULC certified only (ULC-S636)
	PVC-DWV	ANSI/ASTM D2665	
	CPVC schedule 40	ANSI/ASTM F441	
	ABS-DWV sched. 40	ANSI/ASTM D2661	
Pipe cement /primer	PVC	ANSI/ASTM D2564	
	CPVC	ANSI/ASTM F493	
	ABS	ANSI/ASTM D2235	

C 950 ES Electrical Specifications

Electrical Voltage Mains	120V/60Hz
Power Consumption Max Load (A)	≤ 2.5
Idle (mA)	40

C 950 ES Clearances

	Minimum Clearance to Combustibles (Inch)
Front	1
Rear	0
Side	1
Floor	12
Top	12

C 950 ES Degree rise versus flow rate

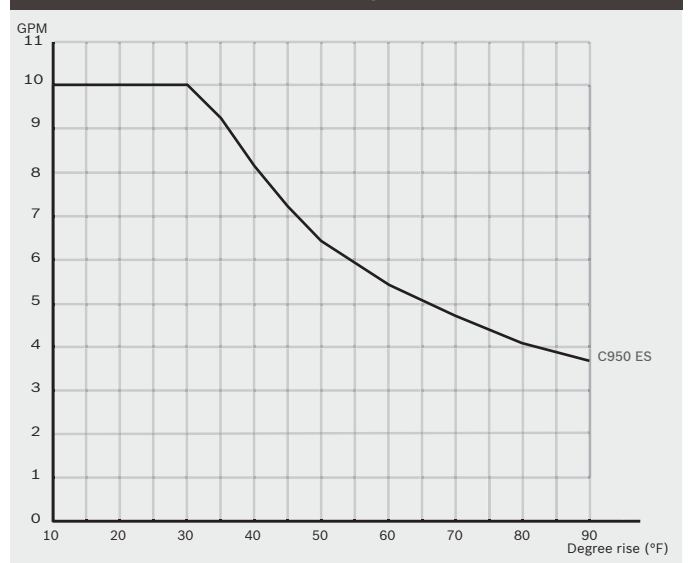

Additional Information

- Low NOx emissions (2012 SCAQMD NOx compliant)
- Modulating water valve for temperature stability
- Modulating premix burner with constant gas/air ratio
- Direct-vent sealed combustion
- Direct spark ignition
- Concentric termination available
- LCD display / control buttons
- 100% copper primary heat exchanger



Options

- Wireless remote control (TSTAT2)
- Condensate neutralization kit (JM2 KIT)
- Cascading kit (77090003962)
- Outdoor kit (BTOK)
- External water filter (8703305356)
- Concentric termination kit (196016)
- Exhaust/Intake bird screen (L2594)
- Pipe Cover (PTPCES)
- High temperature kit (7736500074)
- Recess box kit (7736500043)
- Pressure relief valve (FWL-2)

Note: Refer to installation and applications manual for specific information on venting, piping, electrical connections, and pump sizing.

C 950 ES Piping Specifications	
Exhaust Pipe Diameter	3" or 4"
Combustion Air Pipe Diameter	3" or 4"
Gas Connection Size	¾" NPT
Water Connections	¾" NPT

Note: Exhaust and combustion air connection adaptors are 3" diameter.

Concentric Vent Kit (196016) Parts List		
Description	Length	Quantity
3" Rain Cap	N/A	1
4" Diameter SDR-26 Pipe	24"	1
3" Y Concentric Fitting	N/A	1
2½" Diameter SDR-26 Pipe	37½"	1

C 950 ES Venting Specifications		
	Diameter	Approved Terminals
EXHAUST	3" or 4"	"T" terminal
		90° elbow
		Concentric (196016)
INTAKE	3" or 4"	"T" terminal
		90° elbow
		Concentric (196016)

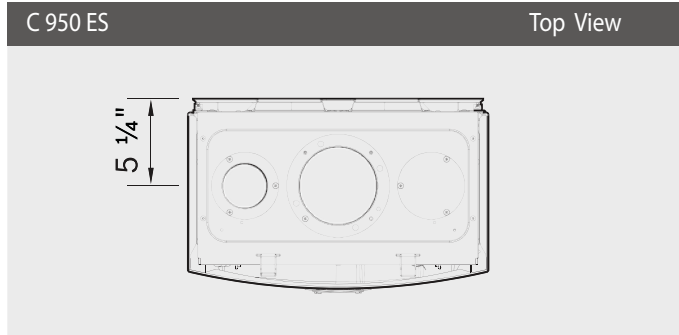

Note: Intake can be installed on the left or right side of the exhaust.

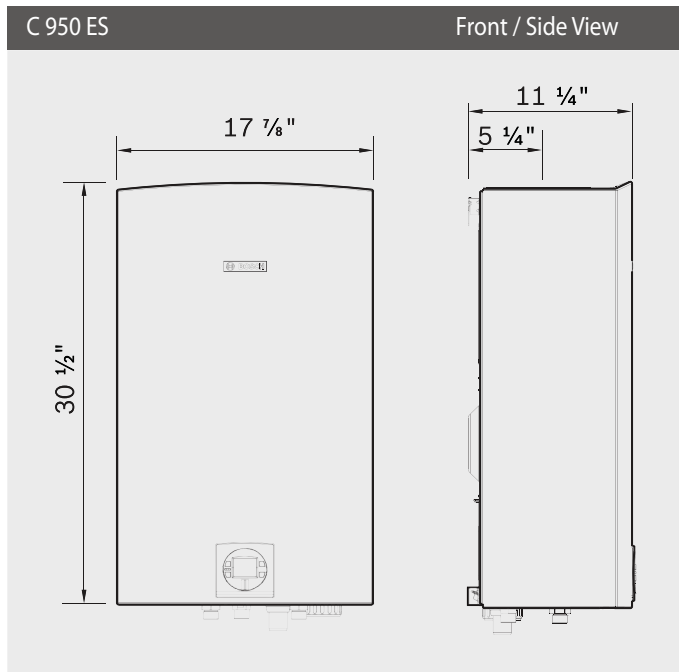
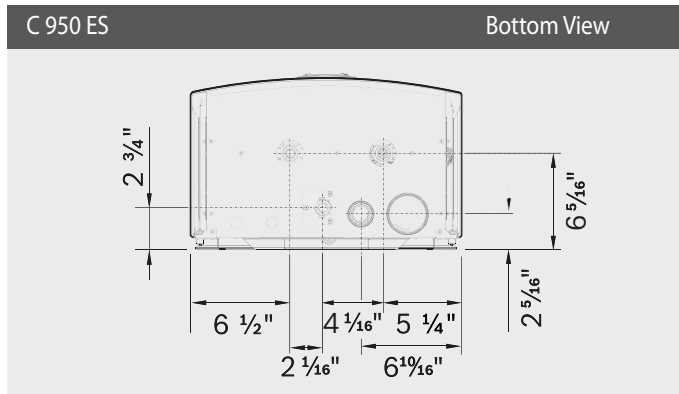

BOSCH

Bosch Thermotechnology Corp.
50 Wentworth Avenue
Londonderry, NH 03053

Tel: 1-866-330-2730
Fax: 1-603-584-1687
www.bosch-climate.us