

C1210ES Tankless Water Heater

Engineering
Submittal
Sheet



BOSCH

Dimensions and Connections

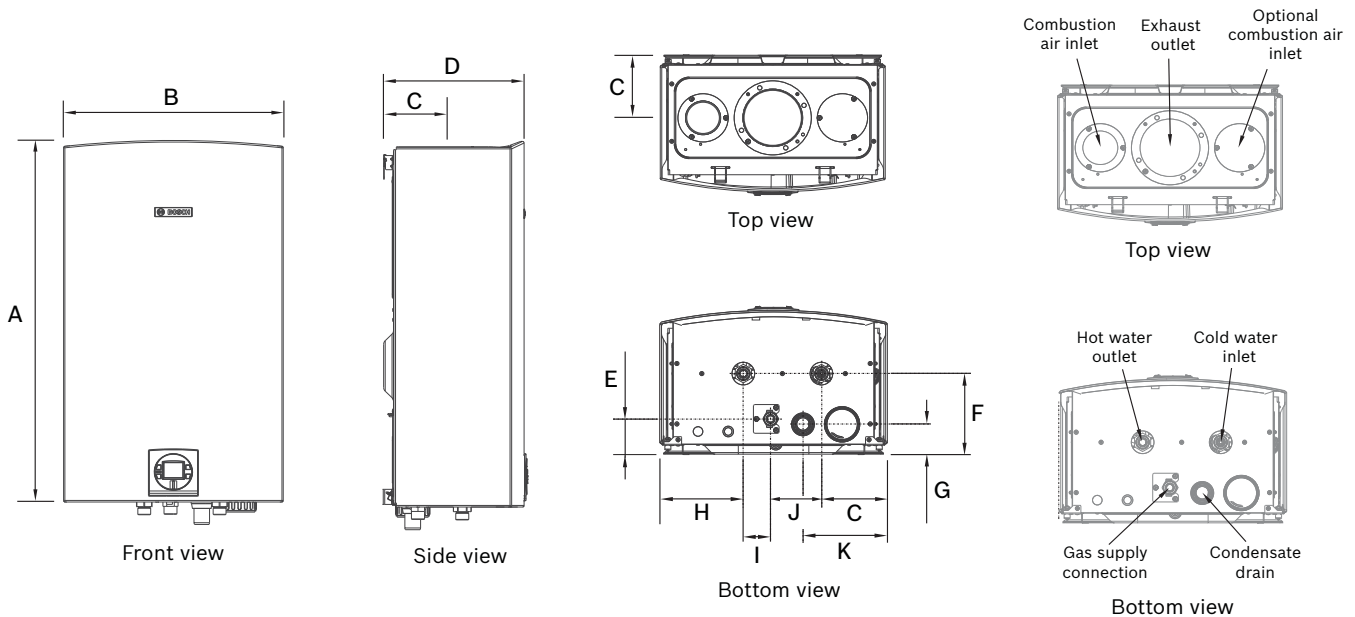

Dimensions

	Unit	A	B	C	D	E	F	G	H	I	J	K
Value	Inches	30½	17⅞	5¼	11¼	2¾	6⅝ ₁₆	2⅝ ₁₆	6½	2⅜ ₁₆	4⅜ ₁₆	6⅝

Engineering Specifications

Water heater shall be a Model Therm C 1210 ES. Plant shall consist of ___ Model Therm C 1210 ES NG/LP tankless water heaters as manufactured by Bosch Thermotechnology Corp. Heater shall be CSA/ANSI Z21.10.3 listed. Heater shall have an input of 225 MBH with a gross output of 211 MBH when fired with natural gas. Unit shall operate with a minimum of 94% ANSI Z-21 efficiency. Tankless water heater shall have a recovery of 329 gallons per hour at a 77°F temperature rise. Tankless water heater shall have Low NOx emissions and is 2012 SCAQMD NOx certified to rule 1146.2.

CONSTRUCTION

Water heater shall be of gas fired, condensing tankless design with a modulating power burner and negative pressure gas valve. Burner shall be capable of 9:1 turndown of firing, without loss of combustion efficiency. Primary heat exchanger/combustion chamber shall incorporate a multi pass copper tube and fin design with internal turbulators. Secondary condensing heat exchanger shall incorporate a multi-pass aluminum heat exchanger of fin tube design with copper water path to prevent

galvanic corrosion. Heat exchangers shall be rated for working pressure not less than 145 psig. Exhaust outlet connector shall be of corrosion resistant metal, with a 3" diameter flue connection.

The water heater control system shall be a single printed circuit board in water-resistant plastic enclosure. The entire system shall be Underwriters Laboratories approved.

The control system shall contain: embedded control board incorporating LCD display to read temperature, and tactile buttons for output power, temperature, and programming control; CPU board which houses all control functions; power transformer; ignition spark module; and unique connections for each sensor or component. The control board shall be field replaceable. The combustion safeguard/flame monitoring system shall utilize spark ignition and a rectification type flame sensor. The control panel hardware shall support wireless remote communications if the wireless module is installed.

Bosch Thermotechnology Corporation
Londonderry, NH • Ft. Lauderdale, FL • Irvine, CA

C1210ES Tankless Water Heater



Engineering Specifications

The controls shall include extensive self-diagnostic capabilities that incorporate a minimum of 18 separate fault codes and 8 programmable system categories.

The water heater comes equipped with power cord and shall operate on 120V/1/60Hz electrical service.

INSTALLATION

All aspects of installation of Water Heater Plant shall be in strict accordance with manufacturer's instructions. Materials shall conform to all manufacturer's recommendations including a manufacturer listed vent system.

Water heater plant piping shall be field constructed of materials as specified. Water heater shall be installed with individually isolating shutoff valves for service and maintenance, and a hot water hose connection for field testing. Unit shall have an ASME approved temperature/pressure relief valve with a setting of 150 psig. Water heater shall require a minimum gas pressure of 3.5" W.C. (Natural Gas) at 1,000 scfh (full load rated capacity).

MODE OF OPERATION

Heater shall include integral factory wired operating controls to control all operation and energy input. Control of discharge water temperature shall be set through an internal setpoint with a field adjustment of 100°F to 140°F. Heater shall be capable of maintaining the outlet temperature within an accuracy of $\pm 3^\circ\text{F}$. This shall be accomplished by modulation of firing rate from 100% to 11% of rated input. Unit shall operate with an

Inverse Efficiency Curve, with maximum efficiency achieved at minimum firing input.

CONTROLS INTEROPERABILITY

The control board may be linked to other Bosch tankless water heaters through the use of a cascading kit. This accessory shall cause the unit to perform as described above while activating or deactivating other units in the system. Additional Bosch tankless water heaters shall be plumbed in parallel and located near the main unit.

WARRANTY

The heat exchangers shall carry a 15-year warranty against leakage due to defects in materials or workmanship or corrosion in a residential, non-direct recirculation system, subject to the manufacturer's water quality requirements. All other parts and components shall carry a 5 year warranty against defects in materials or workmanship.

OR

The heat exchangers shall carry a 5-year warranty against leakage due to defects in materials or workmanship or corrosion in a commercial installation, subject to the manufacturer's water quality requirements. All other parts and components shall carry a 5 year warranty against defects in materials or workmanship.

Performance Data

	Unit	Value
Maximum gas input	BTU	225,000
Minimum input	BTU	25,000
Maximum output	BTU	210,000
Minimum output	BTU	23,000
Thermal efficiency	%	94

C1210ES

Tankless Water Heater



BOSCH

Operational Data		
	Unit	Value
C 1210 ES NG / Natural Gas - part number	-	7703311073
C 1210 ES LP / Liquid Propane - part number	-	7703411071
Weight	LBS	88
Electrical voltage mains	VAC / Hz	120 / 60
Power consumption max load	A	≤ 2.5
Power consumption idle	mA	40
Min. Inlet gas pressure NG / LP	Inch W.C.	3.5 / 8
Max. Inlet gas pressure NG / LP	Inch W.C.	10.5 / 13
C1210ES Maximum Output Temperature	°F	140
Max. Working pressure	PSI	145
Min. Working pressure	PSI	30
Min. Activation rate	GPM	0.5
Relief valve pressure rating	PSI	150
Venting category	-	IV
Approved vent or combustion air pipe material - United States	-	PVC schedule 40, PVC-DWV, CPVC schedule 40, ABS-DWV sched. 40
Approved vent or combustion air pipe material - Canada	-	CSA or ULC certified only (ULCS636)

Clearances

Top View

Front View

Description	Unit	Minimum clearance
Side clearance W1	Inch	1
Front clearance W2*	Inch	1
Top clearance W3	Inch	12
Floor clearance W4	Inch	12
Rear clearance W5	Inch	0

* 24 inches recommended for servicing.

Required direct vent terminal clearances (twin pipe / concentric penetration)

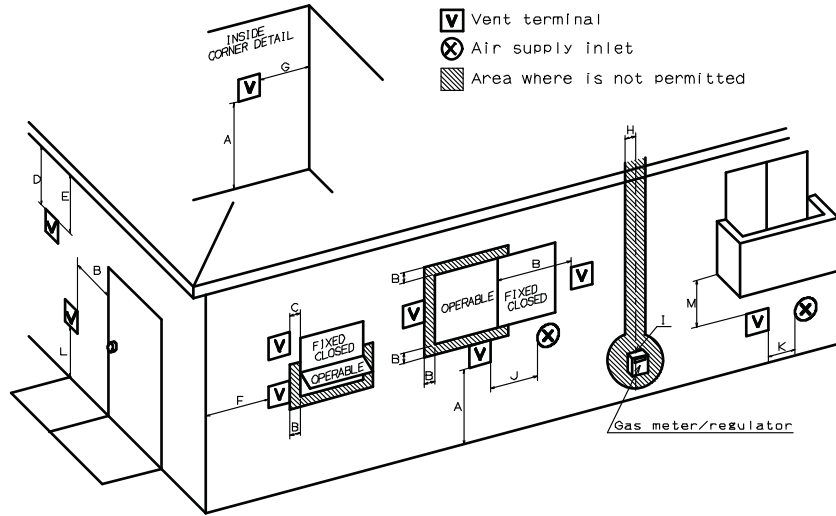

Clearance Data

Item	Description	Value	Canadian installations ¹⁾	U.S. installations ²⁾
A	Clearance above grade, veranda, porch, deck or balcony	Inch	12	12
B	Clearance to window or door that may be opened	Inch	36	12
C	Clearance to permanently closed window	Inch	*	*
D	Vertical clearance to ventilated soffit located above the vent terminator within a horizontal distance of 2 feet (61cm) from the center line of the terminator	Inch	*	*
E	Clearance to unventilated soffit	Inch	*	*
F	Clearance to outside corner	Inch	*	*
G	Clearance to inside corner	Inch	*	*
H	Clearance to each side of center line extended above meter/regulator assembly	-	36 in. within a height 15 feet above meter/ regulator assembly	*
I	Clearance to service regulator vent outlet	Inch	36	*
J	Clearance to non-mechanical air supply inlet to building or the combustion air inlet to any other application	Inch	36	*
K	Clearance to mechanical air supply inlet	Inch	72	36 in. above if within 10 feet horizontally
L	Clearance above paved sidewalk or paved driveway located on public property	Inch	84 ³⁾	*
M	Clearance under veranda, porch deck or balcony	Inch	12 ⁴⁾	*

1) In accordance with the current CSA B149.1 Natural Gas and Propane Installation Code

2) In accordance with the current ANSI Z223.1 / NFPA 54 National Fuel Gas Code

3) A vent shall not terminate directly above a sidewalk or paved driveway that is located between two single family dwellings and serves both dwellings.

4) Permitted only if veranda, porch, deck or balcony is fully open on a minimum of two sides beneath the floor.

* For clearances not specified in ANSI Z223.1 / NFPA 54 or CSA-B149.1, one of the following shall be indicated:

a) A minimum clearance value determined by testing in accordance with section 2.20, or;

b) A reference to the following footnote:

"Clearance in accordance with local installation codes and the requirements of the gas supplier."

Required other than direct vent terminal clearances (single pipe penetration)

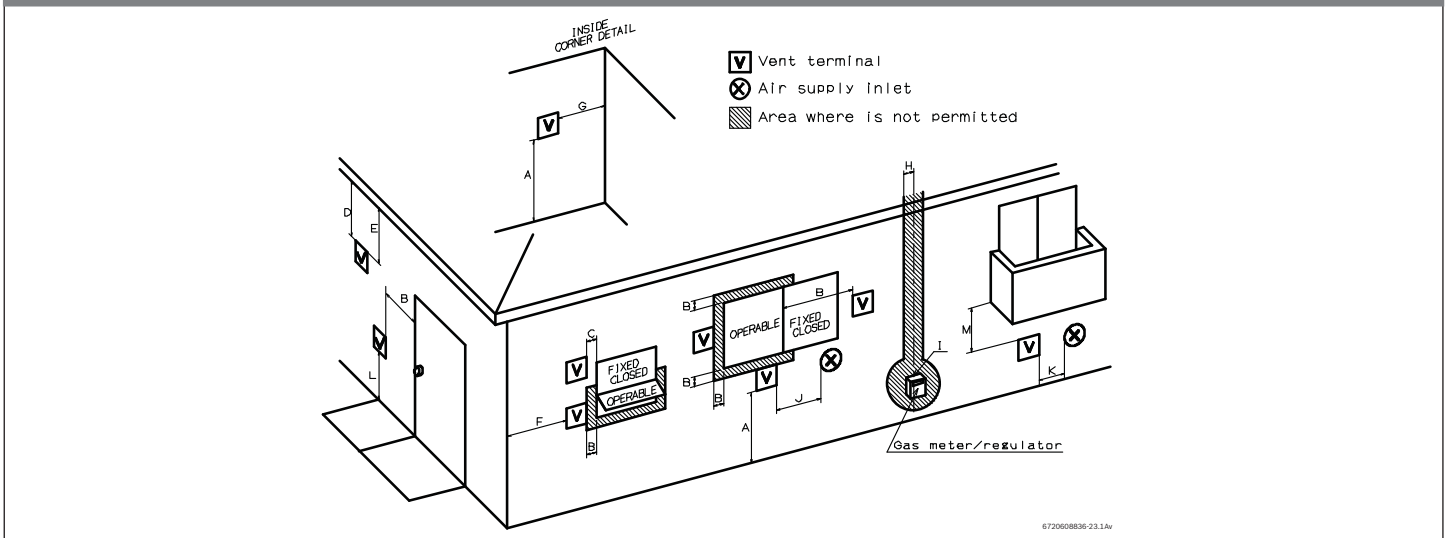

6720658836-23.1Av

Clearance Data

Item	Description	Value	Canadian installations ¹⁾	U.S. installations ²⁾
A	Clearance above grade, veranda, porch, deck or balcony	Inch	12	12
B	Clearance to window or door that may be opened	Inch	36	4 feet below or to side of opening; 1 foot above opening
C	Clearance to permanently closed window	Inch	*	*
D	Vertical clearance to ventilated soffit located above the vent terminator within a horizontal distance of 2 feet (61cm) from the center line of the terminator	Inch	*	*
E	Clearance to unventilated soffit	Inch	*	*
F	Clearance to outside corner	Inch	*	*
G	Clearance to inside corner	Inch	*	*
H	Clearance to each side of center line extended above meter/regulator assembly	-	36 in. within a height 15 feet above meter/regulator assembly	*
I	Clearance to service regulator vent outlet	Inch	36	*
J	Clearance to non-mechanical air supply inlet to building or the combustion air inlet to any other application	Inch	36	4 feet below or to side of opening; 1 foot above opening
K	Clearance to mechanical air supply inlet	Inch	72	36 in. above if within 10 feet horizontally
L	Clearance above paved sidewalk or paved driveway located on public property	Inch	84 ³⁾	84
M	Clearance under veranda, porch deck or balcony	Inch	12 ⁴⁾	*

1) In accordance with the current CSA B149.1 Natural Gas and Propane Installation Code

2) In accordance with the current ANSI Z223.1 / NFPA 54 National Fuel Gas Code

3) A vent shall not terminate directly above a sidewalk or paved driveway that is located between two single family dwellings and serves both dwellings.

4) Permitted only if veranda, porch, deck or balcony is fully open on a minimum of two sides beneath the floor.

* For clearances not specified in ANSI Z223.1 / NFPA 54 or CSA-B149.1, one of the following shall be indicated:

a) A minimum clearance value determined by testing in accordance with section 2.20, or;

b) A reference to the following footnote:

"Clearance in accordance with local installation codes and the requirements of the gas supplier."

Bosch Thermotechnology Corporation
Londonderry, NH • Ft. Lauderdale, FL • Irvine, CA

C1210ES Tankless Water Heater



Water Heating Capacity Curve

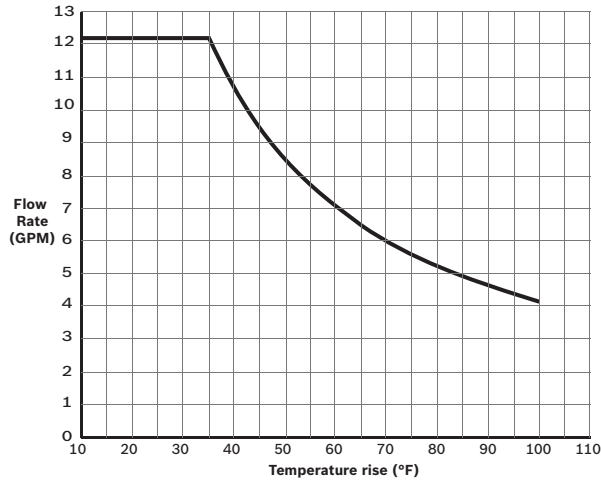

Water Heating Capacity Data

Temperature Rise (°F)	Flow Rate (GPM)
35	12.1
45	9.4
55	7.7
65	6.5
75	5.6
90	4.7
100	4.2

* 35°F capacity is based on installation with a mixing valve to overcome typical pressure loss through the water heater and system.

Tankless Components

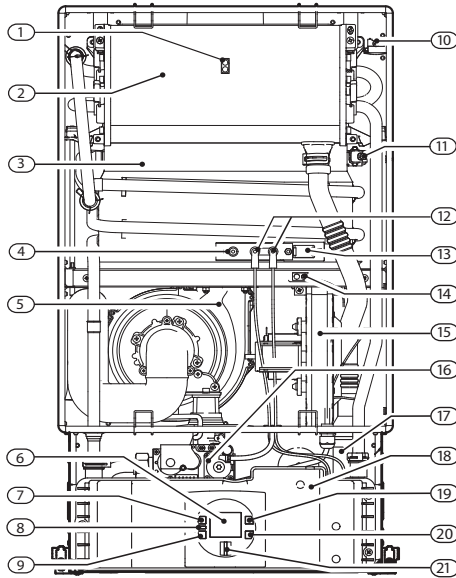

Components Legend

- 1 Exhaust temperature sensor
- 2 Condensing heat exchanger
- 3 Heat exchanger
- 4 Ionization sensor
- 5 Primary fan (Mixer)
- 6 LCD display
- 7 On/Off button
- 8 Reset button
- 9 Program button
- 10 Flue gas limiter
- 11 Heat exchanger overheat sensor (ECO)
- 12 Ignition electrodes
- 13 Observation window
- 14 Backflow temperature sensor
- 15 Secondary air fan
- 16 Gas valve
- 17 Condensate trap
- 18 Control unit
- 19 Up button
- 20 Down button
- 21 LED