

C 1210 ES & C 1210 ESC Gas Condensing Water Heaters

Engineering Submittal Sheet

C 1210 ES/ESC Performance Data

Maximum Gas Input (BTU)	225,000
Minimum Input (BTU)	25,000
Maximum Output (BTU)	210,000
Minimum Output (BTU)	23,000
Thermal Efficiency	94%

C 1210 ES/ESC Operational Data

Weight (lbs.)	88
Min. Inlet Gas Pressure NG("WC) / LP("WC)	3.5 / 8
Max. Inlet Gas Pressure NG("WC) / LP("WC)	10.5 / 13
C1210ES Maximum Output Temperature (°F)	140°F
C1210ESC Maximum Output Temperature (°F)	180°F
Flow Rate at 35°F ΔT (GPM) ¹	12.1
Flow Rate at 45°F ΔT (GPM)	9.4
Flow Rate at 50°F ΔT (GPM)	8.5
Flow Rate at 60°F ΔT (GPM)	7.1
Max. Working Pressure (psi)	150
Min. Working Pressure (psi)	30
Min. Activation Rate (GPM)	0.5
Relief Valve Pressure Rating (psi)	150
Venting Category	IV

¹ 35°F capacity on C 1210 and C 1050 models based on installation with a mixing valve to overcome typical pressure loss through the water heater and system.

C 1210 ES Approved Venting Material

Item	Material	United States	Canada
Vent or air pipe and fitting	PVC schedule 40	ANSI/ASTM D1785	CSA or ULC certified only (ULC-S636)
	PVC-DWV	ANSI/ASTM D2665	
	CPVC schedule 40	ANSI/ASTM F441	
	ABS-DWV sched. 40	ANSI/ASTM D2661	
Pipe cement /primer	PVC	ANSI/ASTM D2564	
	CPVC	ANSI/ASTM F493	
	ABS	ANSI/ASTM D2235	

C 1210 ES/ESC Electrical Specifications

Electrical Voltage Mains	120V/60Hz
Power Consumption Max Load (A)	≤ 2.5
Idle (mA)	40

C 1210 ES/ESC Clearances

	Minimum Clearance to Combustibles (Inch)
Front	1
Rear	0
Side	1
Floor	12
Top	12

C 1210 ES/ESC

Degree rise versus flow rate

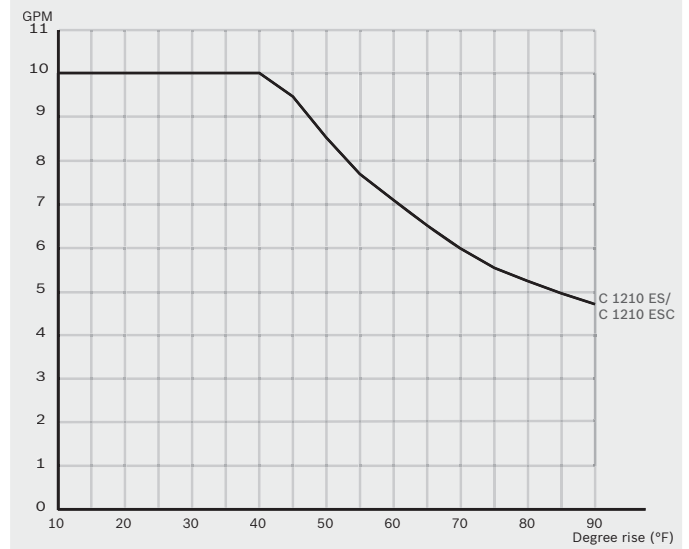

Additional Information

- Low NOx emissions (2012 SCAQMD NOx compliant)
- Modulating water valve to improve temperature stability
- Modulating premix burner with constant gas/air ratio
- Direct-vent sealed combustion
- Direct spark ignition
- 150 psi relief valve
- Concentric termination available
- LCD display with backlight / control buttons
- 100% copper heat exchanger



Options

- Wireless remote control (TSTAT2)
- Condensate neutralization kit
- Cascading kit (77090003962)
- Outdoor kit (BTOK)
- External water filter (8703305356)
- Concentric termination kit (196016)
- Exhaust/Intake bird screen (L2594)
- Pipe Cover (PTPCES)
- Recess box kit (7736500043)
- Pressure relief valve (FWL-2).

C 1210 ES/ESC Piping Specifications	
Exhaust Pipe Diameter	3" or 4"
Combustion Air Pipe Diameter	3" or 4"
GAS Connection Size	¾" NPT
Water Connections	¾" NPT
Relief Valve Connection	¾" NPT

Note: Exhaust & combustion air connection adaptors are 3" diameter.

Concentric Vent Kit (196016) Parts List		
Description	Length	Quantity
3" Rain Cap	N/A	1
4" Diameter SDR-26 Pipe	24"	1
3" Y Concentric Fitting	N/A	1
2½" Diameter SDR-26 Pipe	37½"	1

C 1210 ES/ESC Venting Specifications		
	Diameter	Approved Terminals
EXHAUST	3" or 4"	"T" terminal
		90° elbow
		Concentric (BWH60L46)
INTAKE	3" or 4"	"T" terminal
		90° elbow
		Concentric (BWH60L46)

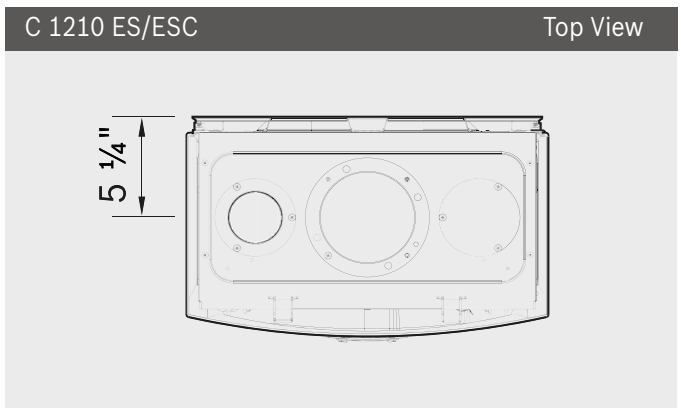

Note: Intake can be installed on the left or right side of the exhaust.

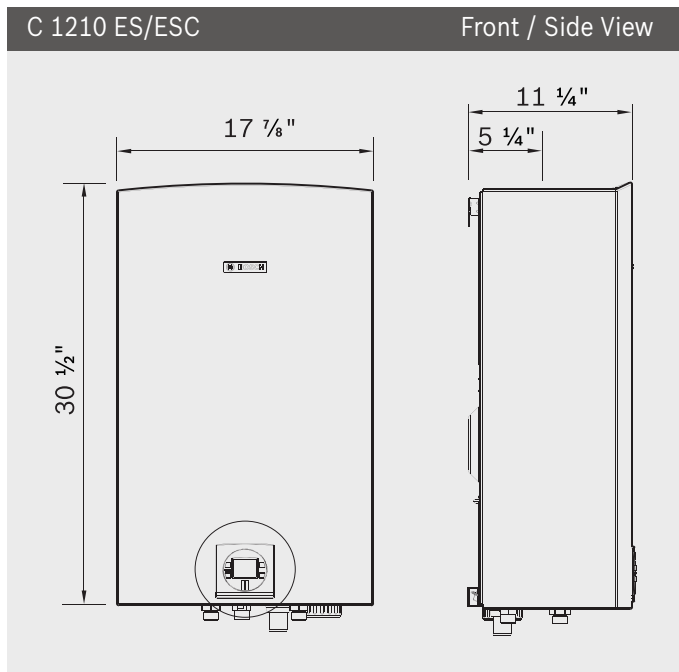
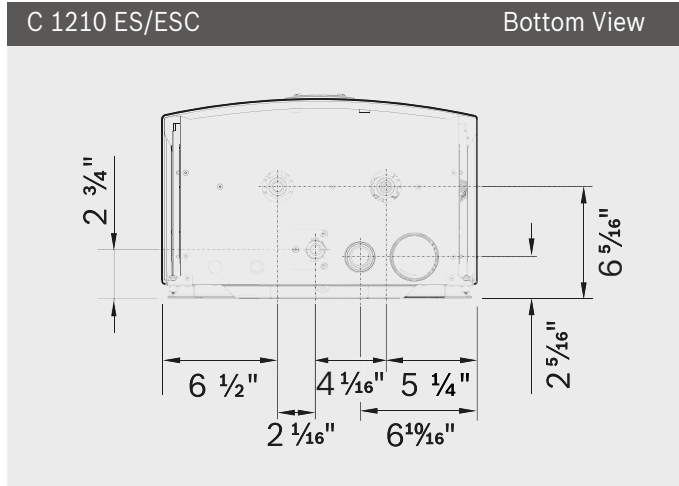

Note: Refer to installation and applications manual for specific information on venting, piping, electrical connections, and pump sizing.



BOSCH

Bosch Thermotechnology Corp.
50 Wentworth Avenue
Londonderry, NH 03053

Tel: 1-866-330-2730
Fax: 1-603-584-1687
www.bosch-climate.us